

Ahsay Online Backup Manager v8

Microsoft Exchange 2013 / 2016 / 2019 (EWS)

Mail Level Backup & Restore Guide

Ahsay Systems Corporation Limited

4 November 2021

Copyright Notice

© 2021 Ahsay Systems Corporation Limited. All rights reserved.

The use and copying of this product is subject to a license agreement. Any other use is prohibited. No part of this publication may be reproduced, transmitted, transcribed, stored in a retrieval system or translated into any language in any form by any means without prior written consent of Ahsay Systems Corporation Limited. Information in this manual is subject to change without notice and does not represent a commitment on the part of the vendor, Ahsay Systems Corporation Limited does not warrant that this document is error free. If you find any errors in this document, please report to Ahsay Systems Corporation Limited in writing.

This product includes software developed by the Apache Software Foundation (<https://www.apache.org/>).

Trademarks

Ahsay, Ahsay Cloud Backup Suite, Ahsay Online Backup Suite, Ahsay Offsite Backup Server, Ahsay Online Backup Manager, Ahsay A-Click Backup, Ahsay Replication Server, Ahsay BackupBox Firmware, Ahsay Universal Backup System and Ahsay NAS Client Utility, Ahsay Mobile are trademarks of Ahsay Systems Corporation Limited.

Amazon S3 is a registered trademark of Amazon Web Services, Inc., or its affiliates.

Apple and Mac OS X, macOS, and iOS are registered trademarks of Apple Computer, Inc.

Dropbox is a registered trademark of Dropbox Inc.

Google Cloud Storage, Google Drive, Google Authenticator, and Android are registered trademarks of Google Inc.

Wasabi Hot Cloud Storage is a registered trademark of Wasabi Technologies Inc.

Backblaze B2 Cloud Storage is a registered trademark of Backblaze Inc.

MariaDB is a registered trademark of MariaDB Corporation AB.

Lotus, Domino, and Notes are registered trademark of IBM Corporation.

Microsoft Windows, Microsoft Exchange Server, Microsoft SQL Server, Microsoft Hyper-V, Microsoft Azure, OneDrive, OneDrive for Business, Microsoft Authenticator, and Microsoft Office 365 are registered trademarks of Microsoft Corporation.

Oracle and Java are registered trademarks of Oracle and/or its affiliates. Other names may be trademarks of their respective owners.

Oracle 11g, Oracle 12c, Oracle 18c, Oracle 19c, and MySQL are registered trademarks of Oracle Corporation.

Rackspace and OpenStack are registered trademarks of Rackspace US, Inc.

Red Hat, Red Hat Enterprise Linux, the Shadowman logo and JBoss are registered trademarks of Red Hat, Inc. www.redhat.com in the U.S. and other countries.

Linux is a registered trademark of Linus Torvalds in the U.S. and other countries.

Ubuntu is a registered trademark of Canonical Ltd.

ShadowProtect is a registered trademark of StorageCraft Technology Corporation.

VMware ESXi, vCenter, and vSAN are registered trademarks of VMware, Inc.

All other product names are registered trademarks of their respective owners.

Disclaimer

Ahsay Systems Corporation Limited will not have or accept any liability, obligation or responsibility whatsoever for any loss, destruction or damage (including without limitation consequential loss, destruction or damage) however arising from or in respect of any use or misuse of reliance on this document. By reading and following the instructions in this document, you agree to accept unconditionally the terms of this Disclaimer and as they may be revised and/or amended from time to time by Ahsay Systems Corporation Limited without prior notice to you.

Revision History

Date	Descriptions	Type of modification
25 January 2021	Updated screenshot in Ch. 2.1.5; Updated PDIC diagram in Ch. 3; Updated login steps in Ch. 4	Modification
7 April 2021	Updated Ch. 3; Added sub-chapters for the detailed process diagrams in Ch. 3.1, 3.2, 3.2.1, 3.2.2 and 3.3	New / Modifications
11 October 2021	Updated login instructions in Ch. 4	Modifications
4 November 2021	Added limitation in Ch. 2.3	New

Table of Contents

1	Overview	5
1.1	Introduction.....	5
1.2	What is this software?	5
1.3	System Architecture	5
1.4	Why should I use AhsayOBM to back up my Mailboxes and Public Folders? ..	7
1.5	About This Document.....	13
1.5.1	Document Main Part.....	13
1.5.2	What should I expect from this document?	14
1.5.3	Who should read this document?	14
2	Preparation for Backup and Restore.....	15
2.1	Requirement.....	15
2.1.1	Software Requirement.....	15
2.1.2	Antivirus Exclusion Requirement	15
2.1.3	Upgrade VMware Tools Requirement	15
2.1.4	AhsayOBM Installation	16
2.1.5	Microsoft Exchange Mailbox Add-On Module	16
2.1.6	AhsayOBM Licenses	16
2.1.7	Backup Quota Requirement.....	17
2.1.8	Continuous Backup Module	17
2.1.9	Java Heap Size	17
2.1.10	Temporary Directory Folder	17
2.1.11	Scheduled Backup for Exchange Server in Data Availability Group (DAG).....	17
2.1.12	Mailbox Role.....	18
2.1.13	Operating System.....	18
2.1.14	Supported Exchange Server 2013 / 2016 / 2019 Version.....	18
2.1.15	Exchange Servers Properties	18
2.1.16	Windows User Account Permission.....	19
2.1.17	Enabling Mailbox	21
2.1.18	Login Name Format Requirement.....	22
2.1.19	Backup Source Requirement	22
2.1.20	Network Drive Requirements	22
2.1.21	Port Configuration	23
2.1.22	Exchange related Windows Services	23
2.1.23	MS Exchange Databases.....	23
2.1.24	Windows PowerShell.....	24
2.1.25	.Net Framework.....	25
2.1.26	Remote Exchange Management Shell	27
2.1.27	LAN Manager Authentication Level	27
2.1.28	IISAuthenticationMethods Setting.....	28

2.2	Supported Source	29
2.3	Limitation	29
2.4	Best Practices and Recommendations	31
3	Overview of MS Exchange Mail Level Backup Process	35
3.1	Periodic Data Integrity Check (PDIC) Process	36
3.2	Backup Set Index Handling Process.....	38
3.2.1	Start Backup Job	38
3.2.2	Completed Backup Job	39
3.3	Data Validation Check Process	40
4	Logging in to AhsayOBM.....	41
4.1	Login to AhsayOBM without 2FA	41
4.2	Login with 2FA using authenticator app.....	43
4.3	Login with 2FA using Twilio.....	46
5	On Exchange Server	48
5.1	Standalone Backup Option	48
5.1.1	Create Mail Level Backup Set.....	48
5.1.2	Run Mail Level Backup Job.....	56
5.1.3	Restore Mail Level Backup	59
5.2	Database Availability Group (DAG) Backup Option	66
5.2.1	Create Mail Level Backup Set.....	66
5.2.2	Run Mail Level Backup Job.....	74
5.2.3	Restore Mail Level Backup	75
6	On Remote Backup Machine	82
6.1	Standalone Backup Option	82
6.1.1	Create Mail Level Backup Set.....	82
6.1.2	Run Mail Level Backup Job.....	90
6.1.3	Restore Mail Level Backup	92
6.2	Database Availability Group (DAG) Backup Option	99
6.2.1	Create Mail Level Backup Set.....	99
6.2.2	Run Mail Level Backup Job.....	107
6.2.3	Restore Mail Level Backup	110
6.3	Configure Backup Schedule for Automated Backup	116
7	Contact Ahsay	120
7.1	Technical Assistance.....	120
7.2	Documentation	120

1 Overview

1.1 Introduction

This user guide aims at providing detailed information for backing up and restoring individual mail items and public folder items stored in Microsoft Exchange Server 2013 / 2016 / 2019 with AhsayOBM, also known as the Mail Level backup.

Mail Level Backup must be utilized in conjunction with full Information Store Backup as Mail Level backup for Microsoft Exchange Server is not designed to fully protect an Exchange Server, but to facilitate easy backup and fast restoration of individual emails, contacts, calendars or public folder, etc.

AhsayOBM supports standalone backup option and Database Availability Group (DAG) backup option for Exchange server Mail Level backup.

Exchange Server 2013 / 2016 / 2019 Mail Level backup and restore can be performed by installing AhsayOBM either on the Exchange server 2013 / 2016 / 2019 hosting the database or on a remote backup machine.

1.2 What is this software?

Ahsay brings you specialized client backup software, namely AhsayOBM, to provide a set of tools to protect your mailboxes and public folders on Microsoft Exchange Server 2013 / 2016 / 2019. This includes backup and recovery of individual emails, contacts, calendars and other mail items in your mailboxes and public folders, with snapshots / versioning, and retention policy to protect even email that you may have accidentally deleted from your Exchange 2013 / 2016 / 2019 mailboxes or public folders.

1.3 System Architecture

Below is the system architecture diagram illustrating the major elements involved in the backup and restore process among the Microsoft Exchange Server 2013/ 2016 / 2019, AhsayOBM and AhsayCBS.

1. AhsayOBM v8.1.0.0 or above installed on Exchange Server 2013/ 2016 / 2019.

- **Standalone:** The latest version of AhsayOBM is installed on the Exchange server which is connected to AhsayCBS backup server through LAN or internet.

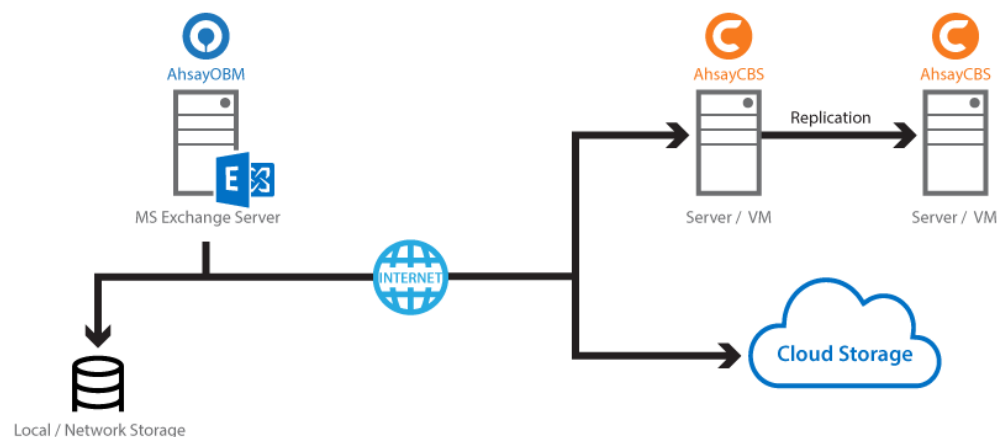

- Database Availability Group (DAG):** The latest version of AhsayOBM is installed on all the DAG members on Exchange server which is connected to AhsayCBS backup server through LAN or internet, and all the DAG members share the same backup set.

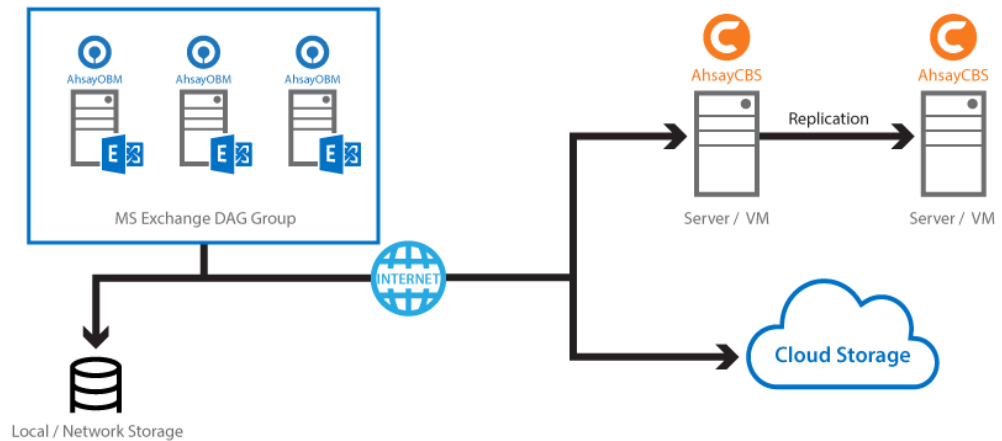

2. AhsayOBM v8.1.0.0 or above installed on Remote Backup Machine.

- Standalone:** The latest version of AhsayOBM is installed on the remote backup machine which is connected to Exchange server and AhsayCBS backup server through LAN or internet.

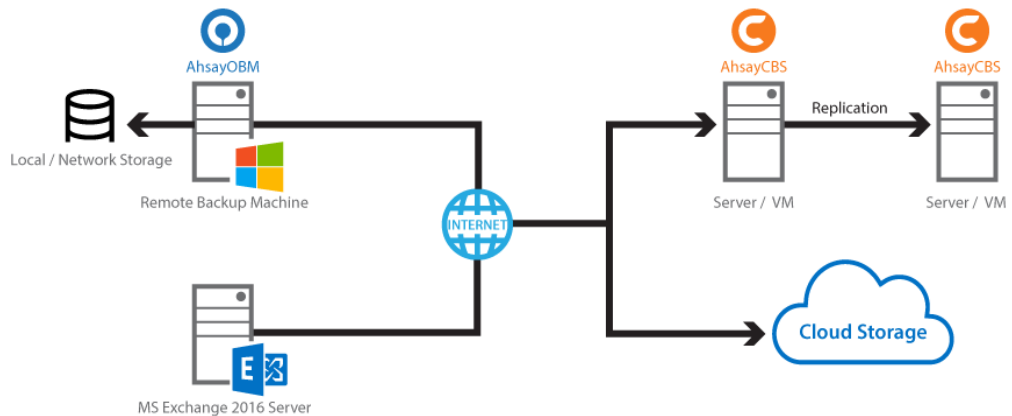

- Database Availability Group (DAG):** The latest version of AhsayOBM is installed on the remote backup machine which is connected to DAG members on Exchange server and AhsayCBS backup server through LAN or internet, and all the DAG members share the same backup set.

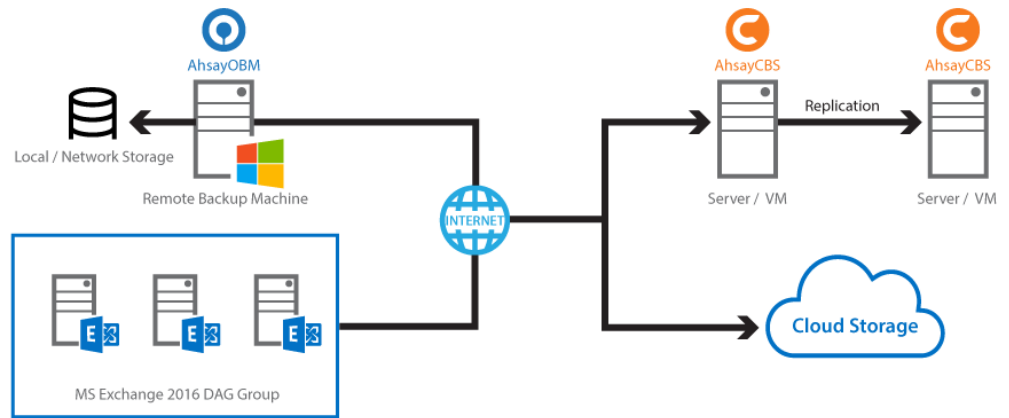

1.4 Why should I use AhsayOBM to back up my Mailboxes and Public Folders?

We are committed to bringing you a comprehensive Exchange 2013 / 2016 / 2019 Mail Level backup solution with AhsayOBM. Below are some key areas that we can help to make your backup experience a better one.

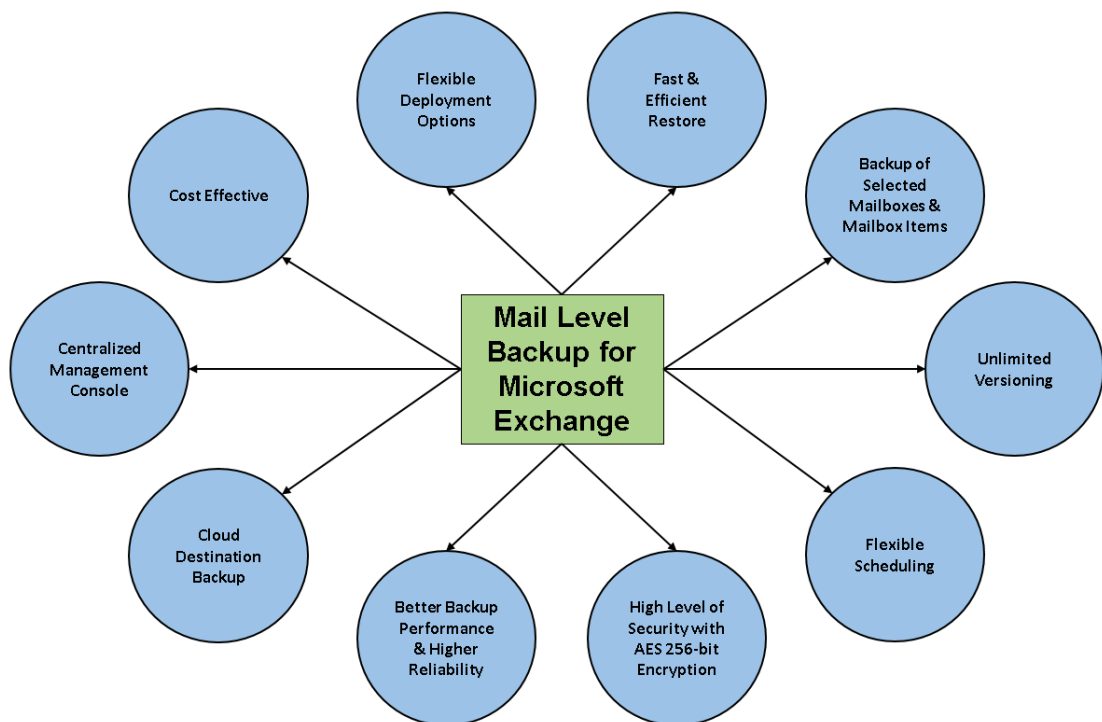

1. Fast and Efficient Restore

We understand that restore could be a time and resources consuming process, which is why AhsayOBM is designed with advanced technologies to make restore a fast and efficient process by restoring individual mail items without the need to restore the whole Exchange server database.

AhsayOBM supports recovery directly to a live production MS Exchange server, so there is no service interruption or downtime incurred, and also the user mailboxes do not have to be disabled and can function normally during the recovery procedure.

2. Backup of Selected Mailboxes & Mailbox Items

The backup resources can be mailbox level, folder level and even item level.

- ⦿ Flexible backup options:
 - Only select the required mailboxes, specific folders or items for backup.
- ⦿ Flexible restore options:
 - Restore the whole mailbox contents or just one email.
 - Restore mail items to the original mailbox or an alternate mailbox
 - Restore mail items to an alternate mailbox on another email domain

3. Unlimited Versioning

AhsayOBM provides backup and restore option for different version of exchange server to fulfill your requirement.

4. Flexible Scheduling

You may wish to run backup at a specified time interval of your choice, that's why we also allow you to set your own backup schedules so that you can take full control of the time when to perform backup.

- ⦿ **Block Level Incremental Backup**—this technology breaks down the backup files into multiple blocks and only the changed blocks will be backed up each time

5. High Level of Security with AES 256-bit Encryption

We understand your Exchange mail objects may contain sensitive information that requires to be protected, that is why your backup data will be encrypted with the highest level of security measure.

- ⦿ **Un-hackable Encryption Key** – to provide the best protection to your backup data, you can turn on the encryption feature which will default encrypt the backup data locally with AES 256-bit truly randomized encryption key.
- ⦿ **Encryption Key Recovery** – Furthermore, we have a backup plan for you to recover your encryption key in case you have lost it. Your backup service provider can make it mandatory for you to upload the encryption key to the centralized management console, the encryption key will be uploaded in hashed format and will only be used when you request for a recovery.

6. Better Backup Performance & Higher Reliability

Better Performance:

- ⦿ **Multi-thread Backup:** The technology utilizes the computing power of multiple CPU cores for creating multiple backup and restore threads to produce fast backup and restore performance.

The default setting for MS Exchange 2013 / 2016 / 2019 mail level backup sets supports:

- Backup of 4 mailboxes concurrently (4 threads).

- For each of the 4 mailboxes, now supports a maximum 4 mail items concurrently (4 threads).

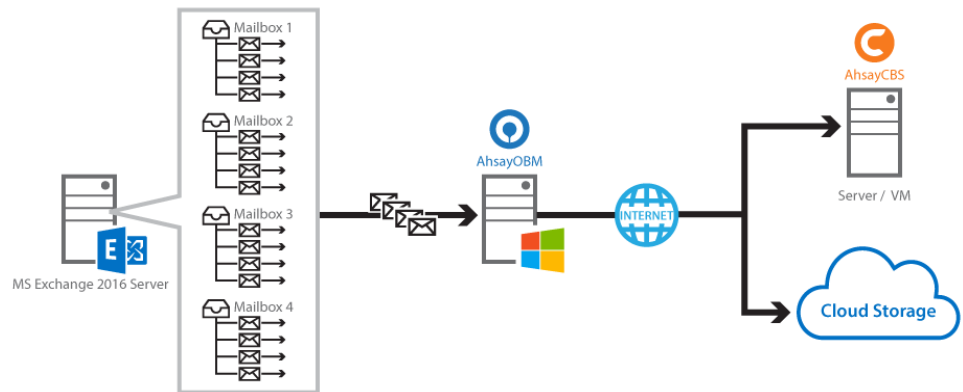

As shown the technology translate into a total of 16 concurrent threads compared with a total 4 concurrent backup threads for Exchange 2007/ 2010/ 2013 mail level backup.

- Index File Structure: The index file structure has been re-designed to improve the backup and restore performance.

Each Exchange 2013 / 2016 / 2019 mailbox will have its own individual index file instead of a single index file for all mailboxes within the backup set.

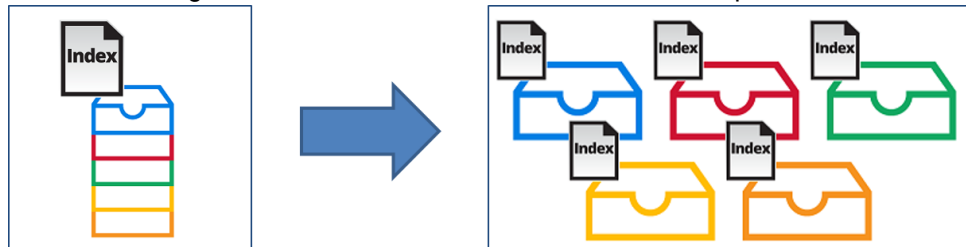

This new design eliminates any potential I/O performance bottlenecks when the index file is updated during each backup job, which can occur when using single index file structure for multi-thread concurrent backup.

Higher Reliability: The implementation of one index file per mailbox can significantly improve the overall resilience of backup and restore from index related issues.

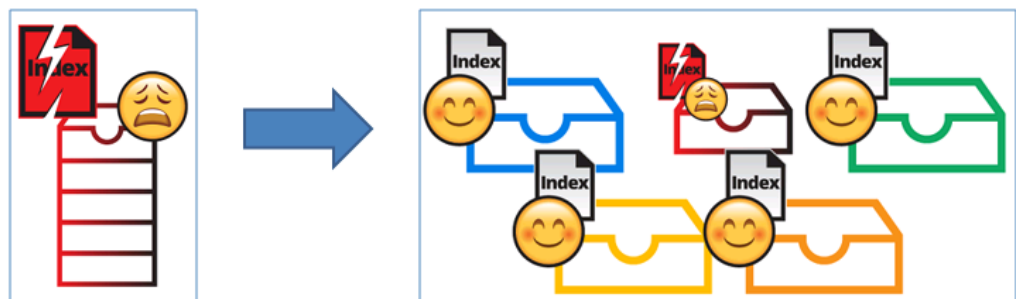

















For example, if a single index file is corrupted, it will only affect the corresponding mailbox, while other mailboxes selected for backup are unaffected.

7. Cloud Destination Backup

To offer you with the highest flexibility of backup destination, you can now back up mail objects to a wide range of cloud storage destinations. Utilizing cloud destination

backup gives you an extra layer of protection in the event of a local drive corruption, where you will still be able to retrieve data from the cloud destination.

Below is a list of supported cloud destinations.

	Aliyun*		Microsoft Azure
	CTYun*		Microsoft OneDrive
	Amazon S3		Microsoft OneDrive for Business
	AWS S3 Compatible Cloud Storage		Rackspace
	Wasabi		OpenStack
	Backblaze		Dropbox
	Google Cloud Storage		FTP
	Google Drive		SFTP

* Available on computers with China or Hong Kong local settings

8. Centralized Management Console

Our enriched features on the centralized web console offers you a one-stop location for monitoring and managing your backup and restore. Below is an overview of what you can do with it. For more details regarding the setup and operations of the centralized management console, refer to the [AhsayCBS User's Guide](#) for details.

- Create / update / delete backup set
- Configure user settings
- Configure backup settings
- View and download backup and restore reports
- Monitor backup and restore live activities
- Monitor storage statistic

9. Cost Effective

License is based on per user mailbox, so you only need to pay for the mailboxes that you wish to backup.

10. Flexible Deployment Options

AhsayOBM supports Mail Level backup and restore of Exchange Server 2013 / 2016 / 2019 by installing the client agent either on the Exchange server hosting the database, or on a remote backup machine.

Below is a comparison table on the differences on backup and restore with AhsayOBM installation on an Exchange server and on a remote backup machine.

	On Server Backup	Remote Backup
Backup	<ul style="list-style-type: none"> ➤ Backup jobs will utilize the Exchange server's resources, so it may impact the server performance. If the load on Exchange server is already high, this can impact the backup performance. ➤ There is minimal performance issue with the transfer of mail items from the Exchange mail store to AhsayOBM. 	<ul style="list-style-type: none"> ➤ Backup jobs will utilize the remote backup machine's resources, therefore, there is minimal impact on the Exchange server performance. ➤ Backup performance can be affected by the network connection speed between the Exchange server and the remote backup machine, especially for connection over the Internet. ➤ General backup performance issues can be easily resolved by installing AhsayOBM on a more powerful backup machine.
Large Number of Mailboxes	<ul style="list-style-type: none"> ➤ Backup of a large number of mailboxes can take more time to complete. <p>For example, it may not be possible to run multiple mail level backup sets concurrently on the Exchange server for 1000 user mailboxes, as it may affect the server performance, so administrator may be limited to start one backup set at a time.</p> <p>1 backup set can only have a total of 16 concurrent threads by default.</p>	<ul style="list-style-type: none"> ➤ Backup of a large number of mailboxes can take less time to complete. <p>For example, 1000 user mailboxes can be divided into 5 separate backup sets of 200 mailboxes each. The 5 backup sets can be started concurrently on 1 machine or started by multiple machines.</p> <p>5 backup sets * 16 concurrent threads = 80 concurrent threads</p>

Backup Scheduling	<ul style="list-style-type: none"> ➤ For environment with limited backup window, there may not be sufficient time to complete both database and mail level backup jobs on a daily basis. 	<ul style="list-style-type: none"> ➤ For environment with limited backup window, remote backup may be a good option as the mail level backup can be completed remotely, while the database backup can be completed on the Exchange server at the same time period. ➤ Continuous backup can be enabled without significant impact on the Exchange server performance, as backup jobs will utilize the resources of the remote backup machine.
Costs	<ul style="list-style-type: none"> ➤ For Exchange DAG setup, the number of AhsayOBM licenses required is equal to the number of DAG members (nodes). For example, if there are 3 DAG members then 3 AhsayOBM licenses are required. ➤ If the Exchange server is already setup for database backups, then there is no additional license cost. ➤ Do not require provision of additional Windows machine. 	<ul style="list-style-type: none"> ➤ Only requires 1 AhsayOBM license as remote backup of Exchange DAG only requires AhsayOBM to be installed on 1 machine. ➤ May require provision of additional Windows machine. It may also be possible to reuse existing AhsayOBM installation on a Windows machine.
Restore	<ul style="list-style-type: none"> ➤ The restore of mailbox items to another (standby) MS Exchange server, requires installation of AhsayOBM on the new MS Exchange server. 	<ul style="list-style-type: none"> ➤ Easily restore mailbox items to another (standby) MS Exchange server, without the need to reinstall AhsayOBM. ➤ Restore mailbox items without direct / physical access to the MS Exchange server. ➤ Restore performance can be affected by any network connection issue between the Exchange server and the remote backup machine, especially if the connection is over the Internet.

1.5 About This Document

1.5.1 Document Main Part

The document can be divided into 3 main parts.

Part 1: Preparation for Exchange 2013 / 2016 / 2019 Mail Level Backup & Restore

Requirements

Requirements on AhsayOBM, Exchange Server 2013 / 2016 / 2019 and Windows Operating System

Supported Backup Source & Limitation

Supported backup source of Exchange Server 2013 / 2016 / 2019 and limitation

Best Practice and Recommendation

Items recommended to pay attention to before backup and restore

Part 2: Perform Mail Level Backup and Restore for Microsoft Exchange 2013 / 2016 / 2019 on Exchange Server

Standalone Backup Option

Create Mail Level backup set, run Mail Level backup job and restore Mail Level backup

Database Availability Group (DAG) Backup Option

Create Mail Level backup set, run Mail Level backup job and restore Mail Level backup

Part 3: Perform Mail Level Backup and Restore for Microsoft Exchange 2013 / 2016 / 2019 on Remote Backup Machine

Standalone Backup Option

Create Mail Level backup set, run Mail Level backup job and restore Mail Level backup

Database Availability Group (DAG) Backup Option

Create Mail Level backup set, run Mail Level backup job and restore Mail Level backup

1.5.2 What should I expect from this document?

After reading through this documentation, you can expect to have sufficient knowledge to set up your system to make Mail Level backup of Exchange Server 2013 / 2016 / 2019 on AhsayOBM, as well as to carry out an end-to-end backup and restore process.

1.5.3 Who should read this document?

This documentation is intended for backup administrators and IT professionals who are responsible for the Exchange Server 2013 / 2016 / 2019 Mail Level backup and restore.

2 Preparation for Backup and Restore

2.1 Requirement

You are strongly recommended to configure or check all the settings below to confirm all the requirements are met before you proceed with the Exchange Mail Level backup and restoration.

2.1.1 Software Requirement

Refer to the following article for the list of compatible operating systems and application versions.

[FAQ: Ahsay Software Compatibility List \(SCL\) for version 8.1 or above](https://wiki.ahsay.com/doku.php?id=public:8014_faq:suggestion_on_antivirus_exclusions)

2.1.2 Antivirus Exclusion Requirement

To optimize performance of AhsayOBM on Windows, and to avoid conflict with your antivirus software, refer to the following article the list of processes and directory paths that should be added to all antivirus software white-list / exclusion list:

https://wiki.ahsay.com/doku.php?id=public:8014_faq:suggestion_on_antivirus_exclusions

NOTE

The bJW.exe process is automatically added to Windows Defender exclusion list for Windows 10 and 2016 during installation / upgrade via installer or upgrade via AUA.

2.1.3 Upgrade VMware Tools Requirement

To avoid unexpected java crash, if the Windows machine is a guest VM hosted on a VMware Host then it is highly recommended that the VMware tools version installed on the guest VM must be 10.0.5 or above.

Below is the warning message that will be displayed if the version of the VMware Tools is less than 10.0.5.

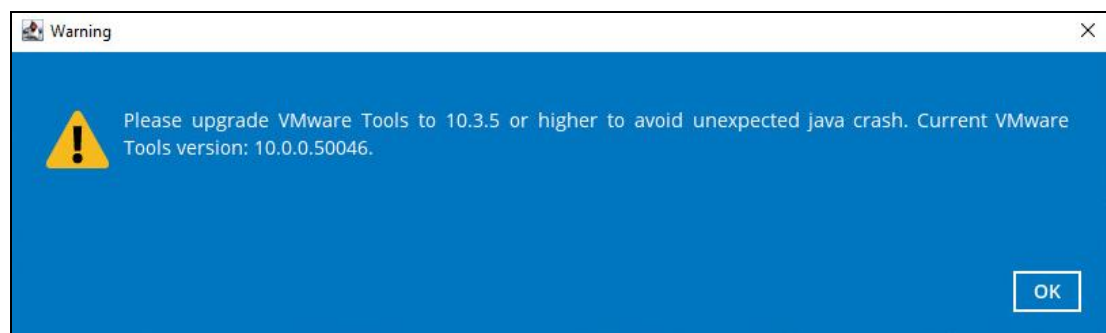

NOTE

For more information about the upgrade of VMware Tools, refer to this article https://wiki.ahsay.com/doku.php?id=public:5288_ahsayobc_crash_on_vm_with_vmware_tools_pre-10.0.5.

2.1.4 AhsayOBM Installation

AhsayOBM v8.1.0.0 or above must be installed either on the Exchange Server 2016 / 2019 hosting the database or on the remote backup machine.

AhsayOBM v8.3.0.96 or above must be installed either on the Exchange Server 2013 hosting the database or on the remote backup machine.

2.1.5 Microsoft Exchange Mailbox Add-On Module

One Microsoft Exchange Mailbox license is required for the backup of each user mailbox. No license is required for public folder.

Make sure the Microsoft Exchange Mailbox feature has been enabled as an add-on module in your AhsayOBM user account and there is sufficient Microsoft Exchange Mailbox license quota to cover the backup of your mailboxes.

Please contact your backup service provider for more details.

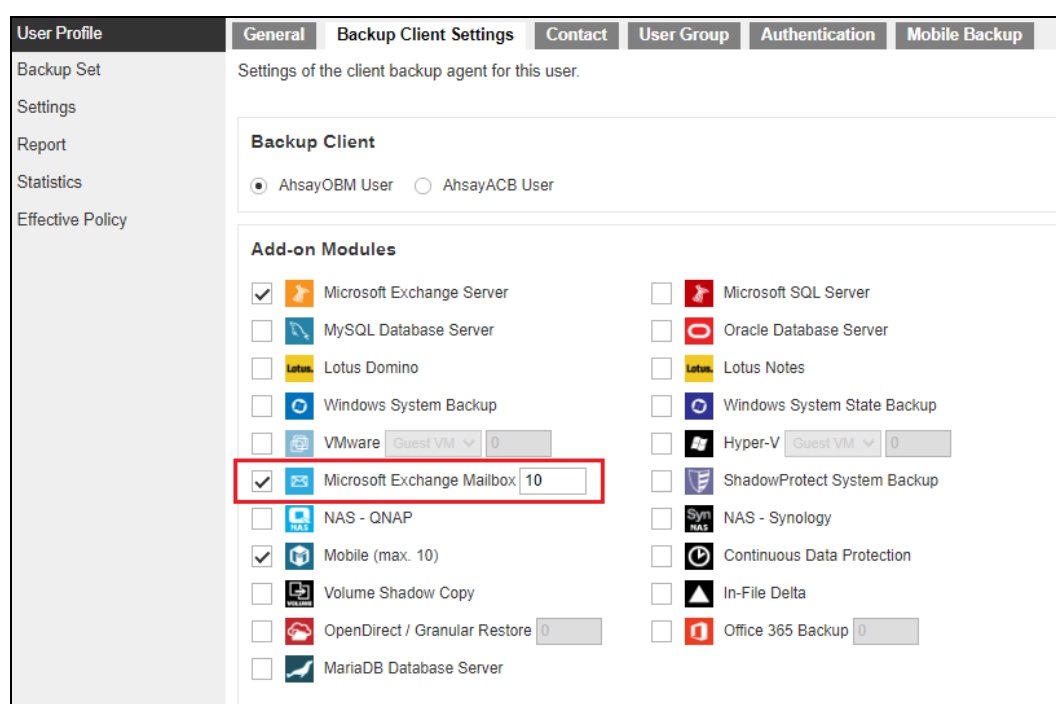

The screenshot displays the 'Backup Client Settings' tab for a user profile. The 'Backup Client' is set to 'AhsayOBM User'. Under the 'Add-on Modules' section, the 'Microsoft Exchange Mailbox' module is checked and has a value of 10. Other modules include MySQL Database Server, Lotus Domino, Windows System Backup, VMware, NAS - QNAP, Mobile (max. 10), Volume Shadow Copy, OpenDirect / Granular Restore, MariaDB Database Server, Microsoft SQL Server, Oracle Database Server, Lotus Notes, Windows System State Backup, Hyper-V, ShadowProtect System Backup, NAS - Synology, Continuous Data Protection, In-File Delta, and Office 365 Backup.

2.1.6 AhsayOBM Licenses

AhsayOBM licenses are calculated on a per device basis.

1. For backup of mailboxes on a standalone Microsoft Exchange 2013 / 2016 / 2019 Server, one AhsayOBM license is required.
2. For backup of mailboxes on a Microsoft Exchange Server 2013 / 2016 / 2019 DAG setup, the number of AhsayOBM licenses required is equal to the number of DAG members in the DAG. For example, if there are three DAG members then three AhsayOBM licenses are required.

Please contact your backup service provider for more details

2.1.7 Backup Quota Requirement

Make sure that your AhsayOBM user account has sufficient storage quota assigned to accommodate the storage of additional Exchange mailbox and public folder items for the new mail level backup set and retention policy.

Please contact your backup service provider for more details.

2.1.8 Continuous Backup Module

The Continuous backup add-on module is required if you would like to enable the continuous backup feature.

2.1.9 Java Heap Size

The default Java heap size setting on AhsayOBM is 2048MB. For Exchange 2013 / 2016 / 2019 mail level backup, it is highly recommended to increase the Java heap size setting to be at least 4096MB to improve backup and restore performance. The actual heap size is dependent on amount of free memory available on your Exchange 2016 / 2019 server.

2.1.10 Temporary Directory Folder

Temporary Directory folder is used by AhsayOBM for storing backup set index files and any incremental or differential delta files generated during a backup job. To ensure optimal backup/restoration performance, it is recommended that the temporary directory folder is located on a local drive with sufficient free disk space.

2.1.11 Scheduled Backup for Exchange Server in Data Availability Group (DAG)

Scheduled backup is required if you choose to back up in DAG option on Exchange server as AhsayOBM on all DAG members will base on the scheduled backup time to start backup on all the individual DAG member at the same time.

1. A DAG backup cycle is considered complete only when scheduled backup on all DAG members have been carried out. An email report will be generated when a complete DAG backup cycle has taken place.
2. Please keep in mind that manual backup will only be considered as individual Mail Level backup, and therefore will not be counted as part of the DAG backup cycle.

However, for backup and restore on a remote backup machine, as the operation for single node can be done either manually or automatically, a scheduled backup is not required.

2.1.12 Mailbox Role

Ensure all nodes have mailbox role. This can be checked by accessing the Exchange admin center (EAC).

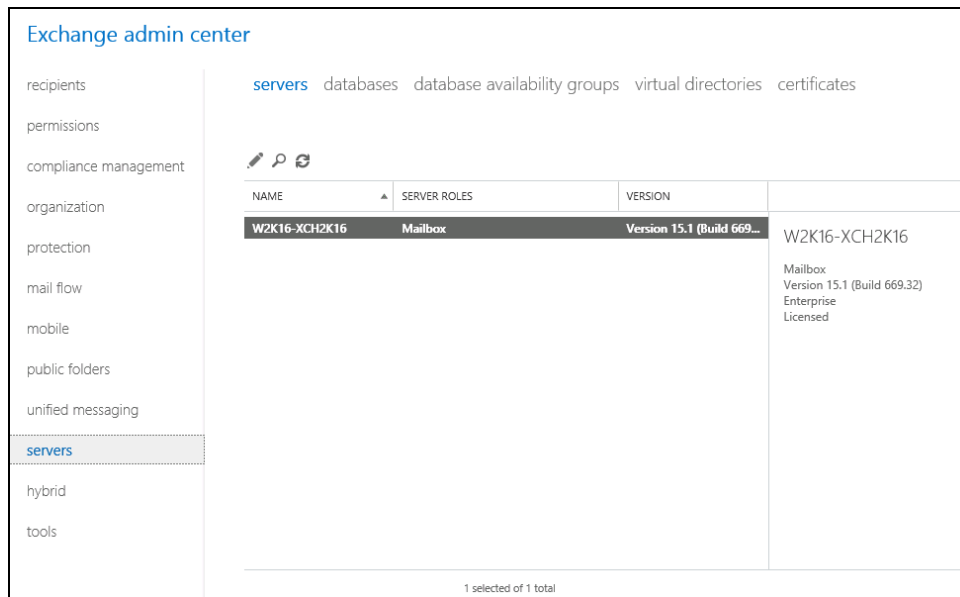

2.1.13 Operating System

1. For AhsayOBM installed on the Exchange Server 2013/2016/2019, the operating system must be Windows Server 2012/ 2012 R2/ 2016 / 2019 or above.
2. For AhsayOBM installed on the remote backup machine, the operating system must be Windows 7/ 8/ 8.1/ 10 or Windows Server 2008/ 2008 R2/ 2012/ 2012 R2/ 2016 / 2019 or above.

2.1.14 Supported Exchange Server 2013 / 2016 / 2019 Version

- MS Exchange Server 2013 Cumulative Update 3 (CU3) or later is supported.
- MS Exchange Server 2016 Cumulative Update 4 (CU4) or later is supported.
- MS Exchange Server 2019 Cumulative Update 1 (CU1) or later is supported

2.1.15 Exchange Servers Properties

To check the properties of Exchange Servers, use the Get-ExchangeServer cmdlet found in the Exchange Management Shell.

Example: Get-ExchangeServer | Format-List Name, Edition,AdminDisplayVersion

Please refer to the following Microsoft article for details of MS Exchange build numbers and releases: <https://docs.microsoft.com/en-us/exchange/new-features/build-numbers-and-release-dates?view=exchserver-2019>

2.1.16 Windows User Account Permission

The Windows user account used for the backup must be a member of the following security groups.

Exchange Server 2013/2016/2019

- Discovery Management (including ApplicationImpersonation and Mailbox Search)

The screenshot shows the Exchange Admin Center interface on the left and a 'Role Group - Internet Explorer' dialog box on the right. The dialog box is for configuring the 'Discovery Management' role group. The 'Name' field is 'Discovery Management'. The 'Description' is 'Members of this management role group can perform searches of mailboxes in the Exchange organization for data that meets specific criteria.' The 'Write scope' is set to 'Default'. The 'Roles' section includes 'ApplicationImpersonation' and 'Mailbox Search'. The 'Members' section includes 'Administrator' and 'Backup'.

- Organization Management

The screenshot shows the Exchange Admin Center interface on the left and a 'Role Group - Internet Explorer' dialog box on the right. The dialog box is for configuring the 'Organization Management' role group. The 'Name' field is 'Organization Management'. The 'Description' is 'Members of this management role group have permissions to manage Exchange objects and their properties in the Exchange organization. Members can also delegate role groups and management roles in the organization. This role group shouldn't be deleted.' The 'Write scope' is set to 'Default'. The 'Roles' section includes 'Active Directory Permissions'. The 'Members' section includes 'Administrator' and 'Backup'.

Public Folder Management

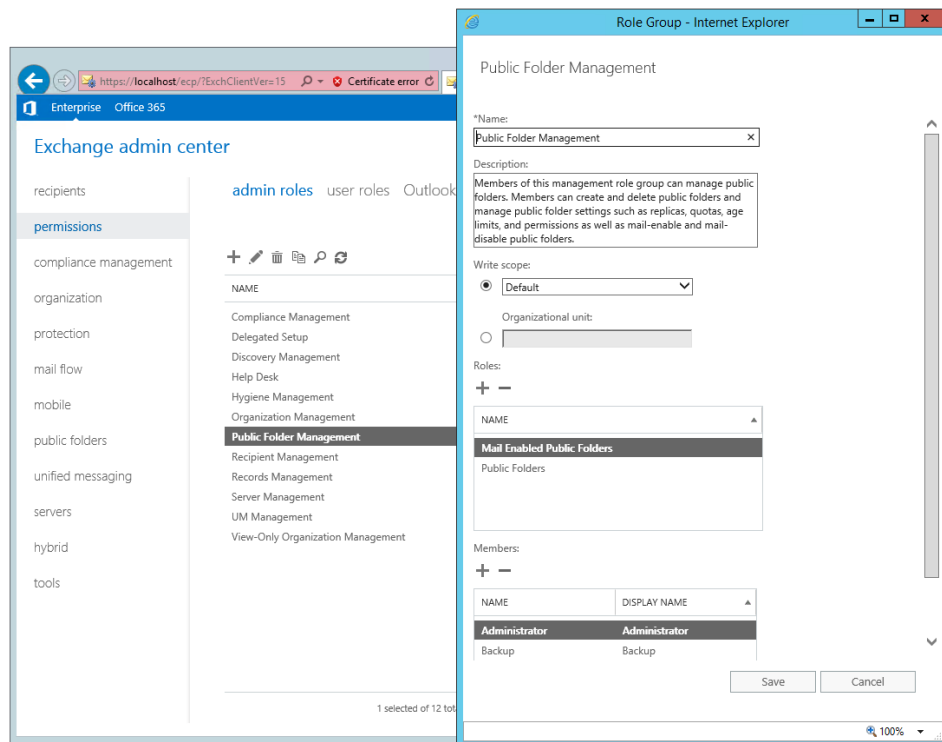

Login to the Exchange admin center, under **permissions, admin roles**. Assign the user to be running the backup as member of the following **admin roles**:

- Discovery Management (including the following **Roles**):
 - ApplicationImpersonation
 - Mailbox Search
- Organization Management
- Public Folder Management

Exchange Server 2013

- Microsoft Exchange Security \ Organization Management
- Users \ Administrator
- Users \ Domain Admins
- Users \ Enterprise Admins

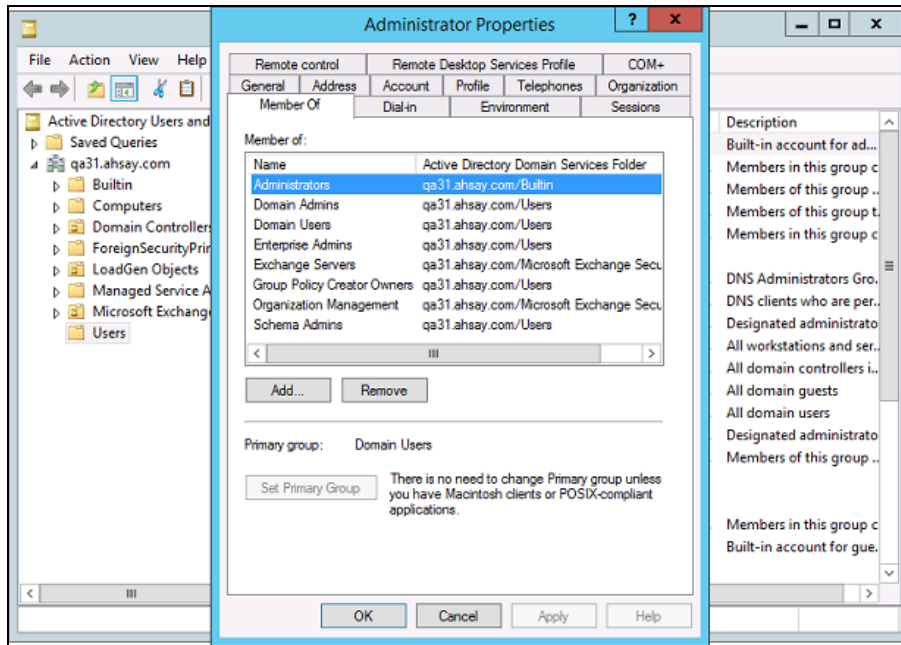

Steps to check the current settings

1. Click Start > **Control Panel** > **Administrative Tools**, and then click **Active Directory Users and Computers**.
2. Browse to the organization unit containing the corresponding operating system account.
3. Right click on the user and select **Properties**.

Select the **Member Of** tab to check on the membership setting.

2.1.17 Enabling Mailbox

The Windows user account must have an Exchange Server mailbox. Refer to the URL below for more information.

Exchange Server 2013/2016/2019

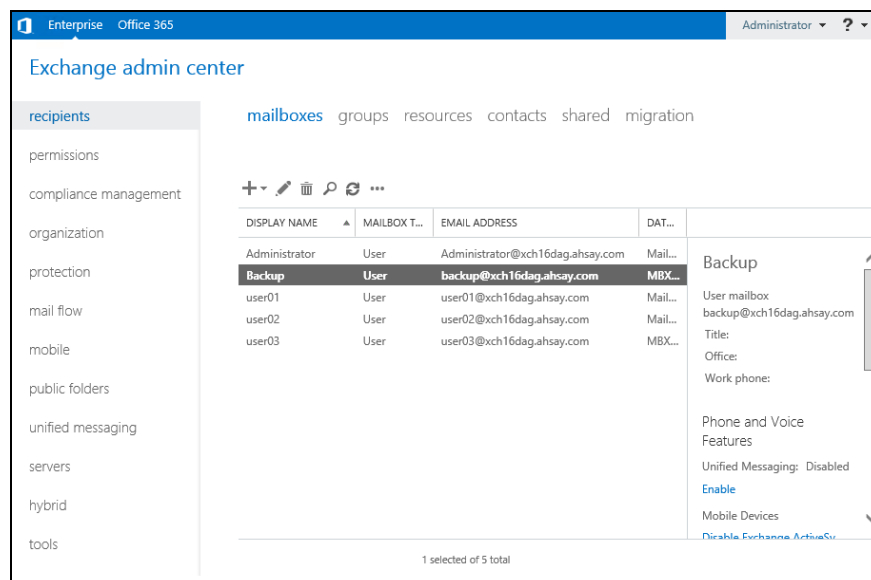

Refer to the following article from Microsoft for more details on how to check if an account is mailbox enabled and how to enable it:

<https://docs.microsoft.com/en-us/Exchange/recipients/create-user-mailboxes?view=exchserver-2019>

Exchange Server 2013

Refer to the following article from Microsoft for more details on how to check if an account is mailbox enabled.

<https://docs.microsoft.com/en-us/exchange/create-user-mailboxes-exchange-2013-help>

Grant Mailbox Access Permission (Full Access)

Enter the following command in the Exchange Management Shell

```
Get-Mailbox | Add-MailboxPermission -User "%os_username%" -AccessRights FullAccess
```

Example: granting permission to “administrator” account

```
Get-Mailbox | Add-MailboxPermission -User “administrator” -AccessRights FullAccess
```

2.1.18 Login Name Format Requirement

Make sure the Username for connecting the Exchange Server is entered in the format of “user@hostname” (e.g. admin@ahsay.local). It is the same one you can find under the mailbox setting of the Exchange user account on Exchange Admin Center.

2.1.19 Backup Source Requirement

Ensure that the “**Hide from address lists**” option is unchecked for all mailboxes to be selected for backup. Mailbox hidden from the address list will not be shown in the backup source selection menu.

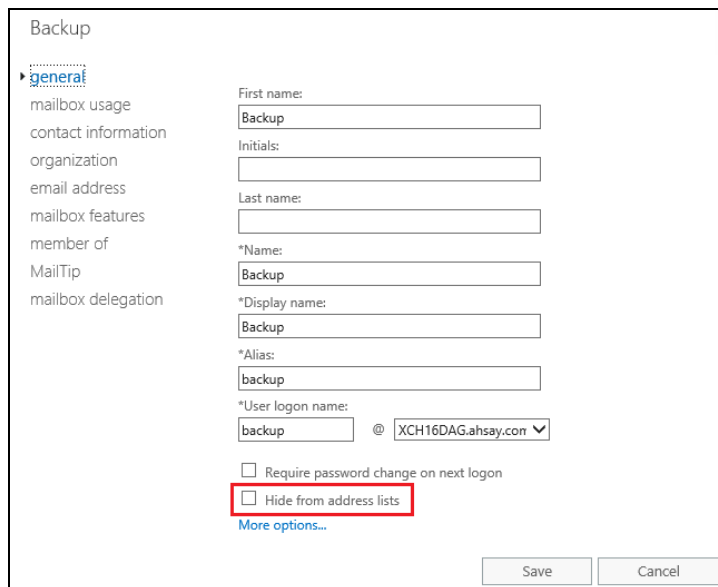

The screenshot shows the 'Backup' mailbox settings in the Exchange Admin Center. The 'general' tab is selected. The following fields are visible:

- First name: Backup
- Initials:
- Last name:
- *Name: Backup
- *Display name: Backup
- *Alias: backup
- *User logon name: backup @ XCH16DAG.ahsay.com
- Require password change on next logon
- Hide from address lists (highlighted with a red box)

At the bottom, there are 'Save' and 'Cancel' buttons. A 'More options...' link is also present.

2.1.20 Network Drive Requirements

The login accounts for network drives must have read and write access permission to ensure that backup and restore would be successful.

2.1.21 Port Configuration

As Exchange 2013 / 2016 / 2019 mail level backup and restore is implemented using Microsoft EWS API (Exchange Web Services), which enables AhsayOBM to access mailbox items such as email message, meetings, notes, calendar, contact, etc., without any additional installation or complicated setup required on the Exchange 2013 / 2016 / 2019 Server or remote backup machine, only **port 443** must be configured to allow communication between AhsayOBM and Exchange server.

2.1.22 Exchange related Windows Services

Ensure all MS Exchange related services have been started, particularly the **MS Exchange Information Store**.

To verify this setting, launch the **Services** menu by clicking **Start** then typing “Services” in the search box. All Exchange related services should be started by default, in case it is not, turn it on by right clicking the item and then select **Start**.

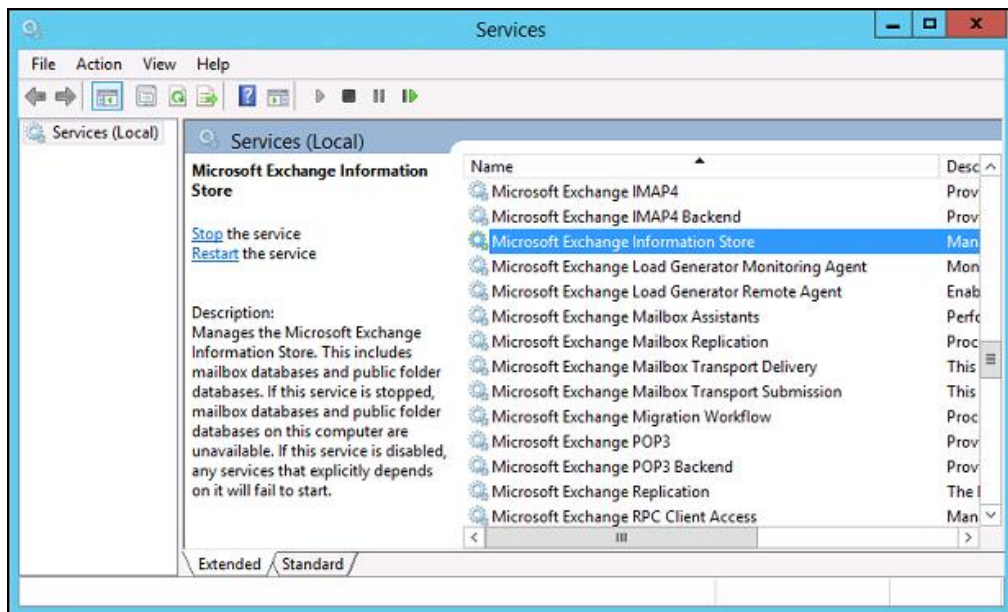

2.1.23 MS Exchange Databases

Ensure the MS Exchange Mailbox and Public Folder databases are mounted. This can be verified by Exchange Management Shell or Exchange Admin Center (EAC).

- Type the following command in the Exchange Management Shell.

```
Get-MailboxDatabase
```

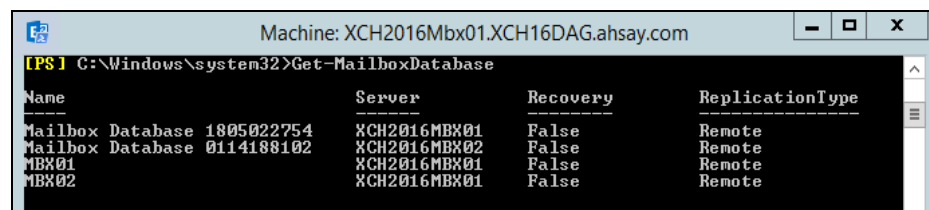

- Exchange Admin Center (EAC)

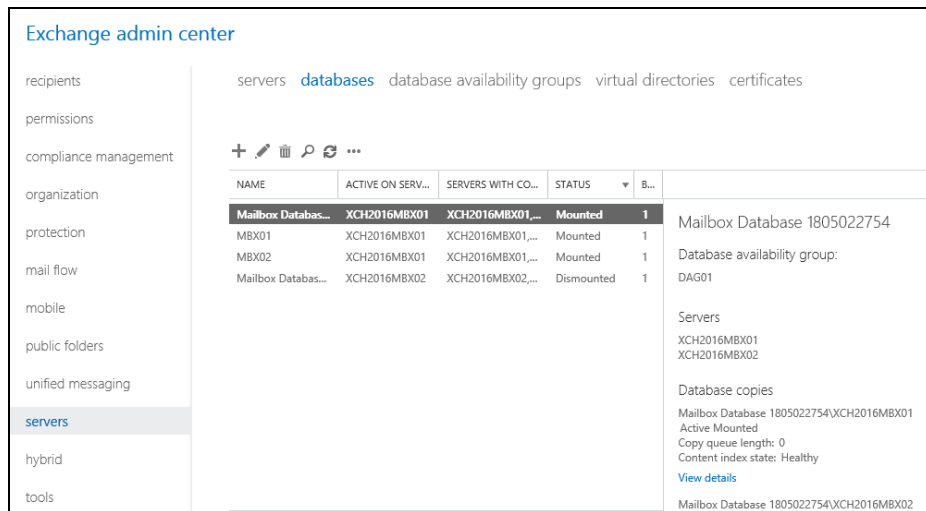

2.1.24 Windows PowerShell

Windows PowerShell 5.1 Engine for Exchange Server 2016/2019

Ensure that Windows PowerShell 5.1 Engine is installed.

To install the feature:

1. Navigate to **Server Manager > Manage**, then select **Add Roles and Features**.
2. On the **Select installation type** screen, select **Role-based or feature-based** installation.
3. **Select** the target server.
4. On the **Select features** screen, go to the **Features** option, check the box next to **Windows PowerShell 5.1 Engine**.

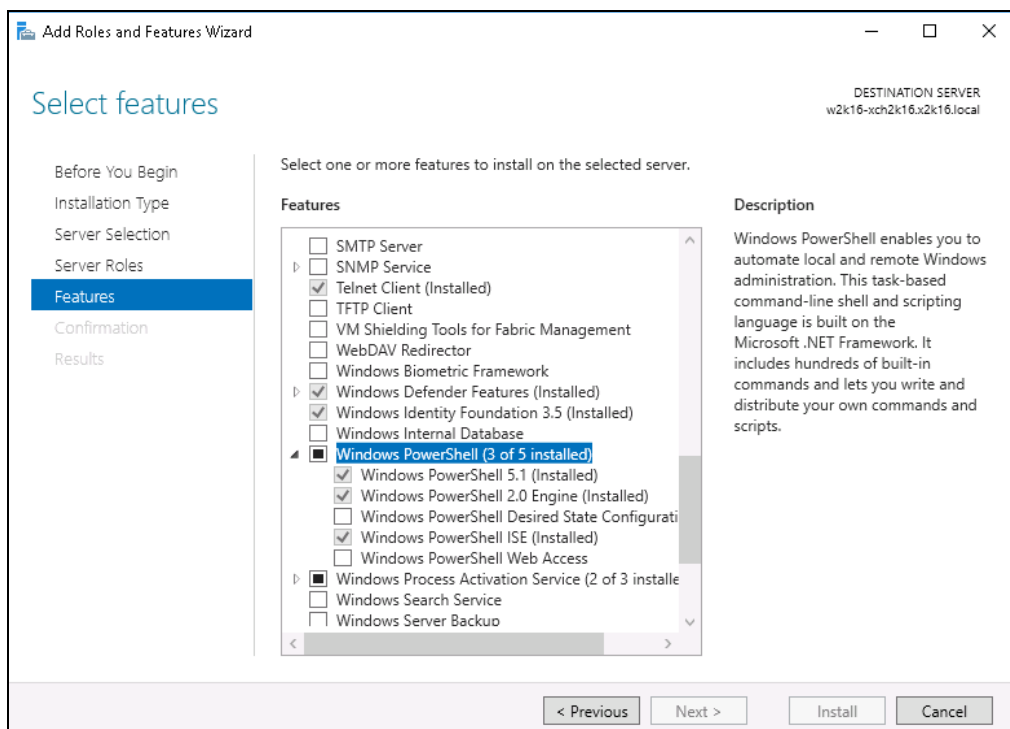

Windows PowerShell 2.0 Engine for Exchange Server 2013

Make sure the Windows PowerShell 2.0 Engine is installed.

To install the feature:

1. Navigate to **Server Manager > Manage**, then select **Add Roles and Features**.
2. On the **Select installation type** screen, select **Role-based or feature-based** installation.
3. Select the target server.
4. On the **Select features** screen, go to the **Features** option, check the box next to **Windows PowerShell 2.0 Engine**.

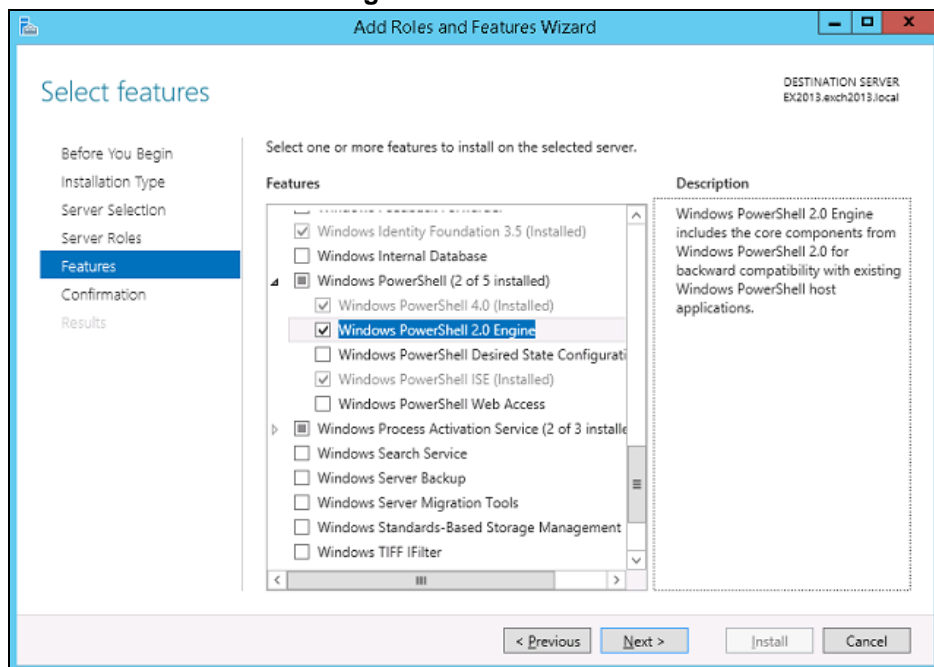

2.1.25 .Net Framework

.Net Framework 4.6.2 Features for Exchange Server 2016/2019

Ensure **.Net Framework 4.6.2 Features** is installed. Please refer to the following URL for detailed information: <https://docs.microsoft.com/en-us/Exchange/plan-and-deploy/system-requirements?view=exchserver-2016>

This feature can be enabled by accessing **Server Manager > Dashboard > Manage > Add Roles and Features Wizard > Feature Page.**

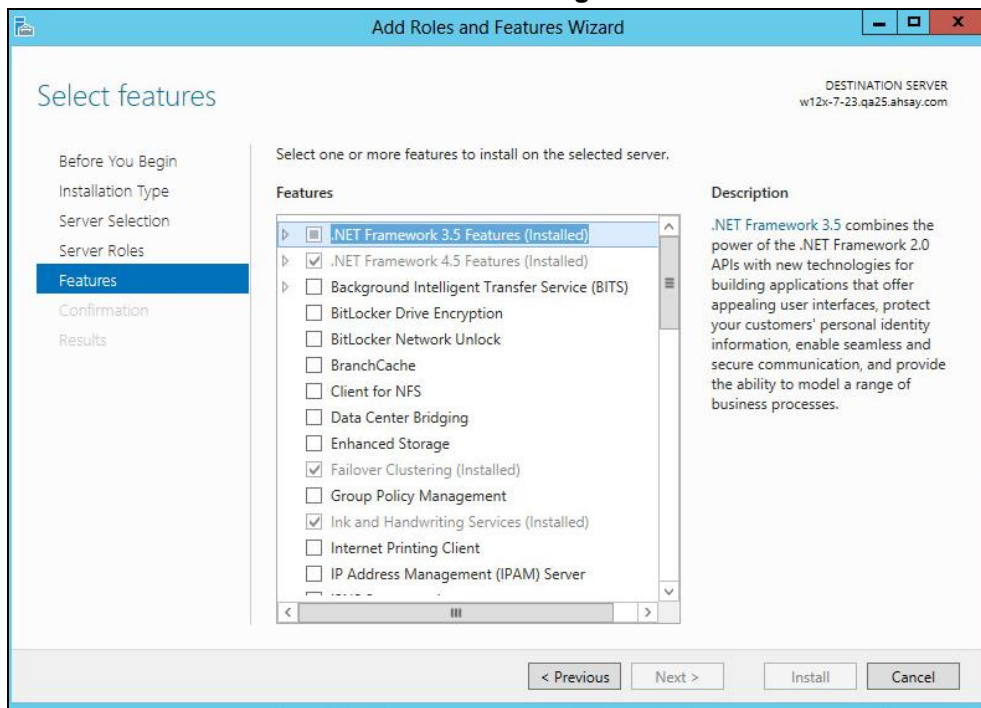

.Net Framework 4.6.2 Features for Exchange Server 2013

If you are using Exchange server 2013 on Windows server 2012, please install **.Net Framework 3.5 Features**.

This feature can be enabled by accessing **Server Manager > Dashboard > Add Roles and Features Wizard > Feature Page.**

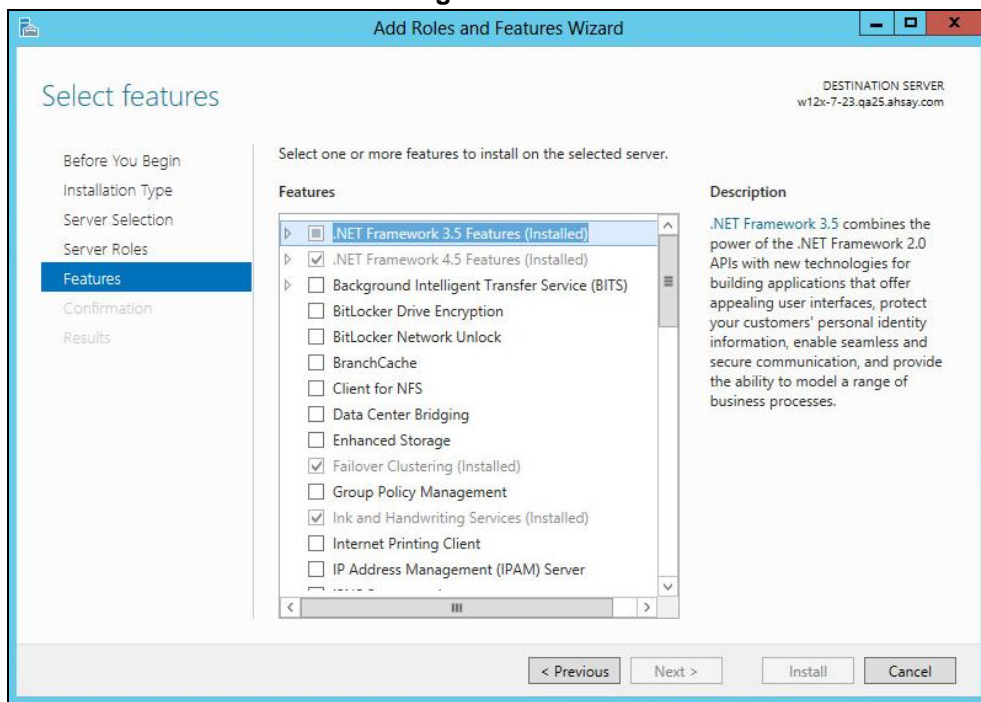

2.1.26 Remote Exchange Management Shell

For setup on MS Exchange Server 2013, the Remote Exchange Management Shell must be enabled for the operating system account used for the backup.

Enter the following command in Exchange Management Shell to enable this feature.

```
>Set-User "%os_username%" -RemotePowerShellEnabled $True
```

Reboot the Exchange Server after executing the command.

NOTE

Remote Shell in Microsoft Exchange Server enables you to manage your server running Exchange.

2.1.27 LAN Manager Authentication Level

Exchange Server 2013

The LAN Manager Authentication level configured on the Exchange Server must be level 3 or above. Follow the steps below to check the settings.

1. Click **Start > Control Panel > Administrative Tools**, and then click **Local Security Policy**.

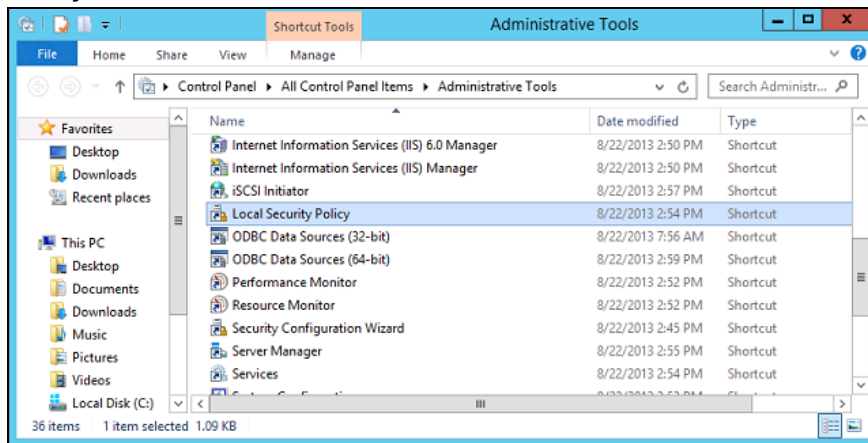

2. Under **Security Settings**, expand **Local Policies > Security Options**, then click **Network security: LAN Manager authentication level**.
3. Make sure that the setting is configured to use NTLMv2, for example:
 - Send NTLMv2 response only
 - Send NTLMv2 response only. Refuse LM
 - Send NTLMv2 response only. Refuse LM & NTLM

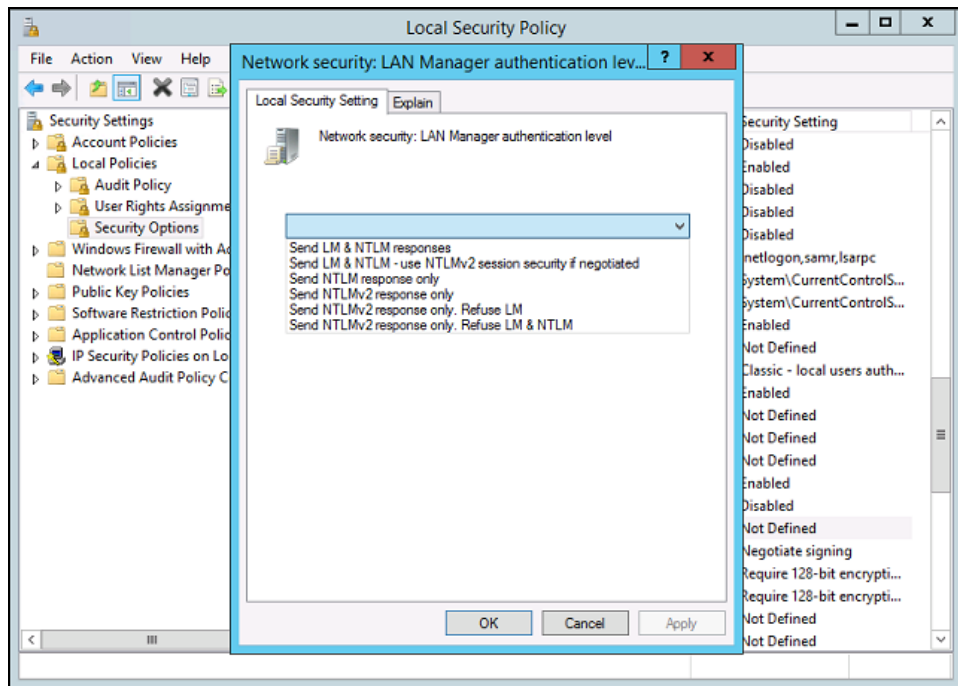

2.1.28 IISAuthenticationMethods Setting

Verify if the IISAuthenticationMethods is set to **Basic** only. If so, change the setting with the commands below.

Exchange Server 2013

1. Click **Start > Microsoft Exchange Server > Exchange Management Shell**.
2. Enter the following command to check on the IISAuthenticationMethods setting:

```
>Get-OutlookAnywhere
```

3. If it is set to {Basic} only, enter the following command to modify the setting:

```
>Set-OutlookAnywhere -Identity:"%Server%\Rpc (Default
Web Site)" -IISAuthenticationMethods
Basic,NTLM,Negotiate
```

4. Reboot the Exchange server.

2.2 Supported Source

Below is the supported mailbox type of Exchange Server 2013 / 2016 / 2019 Mail Level backup.

Mailbox Level			
Item	Supported?	Item	Supported?
User mailbox	✓	Room Mailbox	✓
Public Folder	✓	Equipment Mailbox	✓
Public Folder Mailbox	✓	Shared Mailbox	✓

Below are the items that you can back up or restore from an Exchange Server 2013 / 2016 / 2019 Mail Level backup set.

Folder Level			
Item	Supported?	Item	Supported?
Inbox	✓	RSS Feeds	✓
Drafts	✓	Junk Email	✓
Sent Items	✓	Tasks	✓
Deleted Items	✓	Calendar	✓
Archive	✓	Contacts	✓
Notes	✓		

2.3 Limitation

For backup and restoration of Exchange 2013 / 2016 / 2019 Mail Level backup set, here are some limitations:

1. If you are trying to restore item(s) from one mailbox to an alternate location mailbox, AhsayOBM will restore the item(s) to their respective destination folder(s) with the same name of the original folder(s).

Example: Item from "Inbox" folder of Mailbox-A will be restored to the "Inbox" folder of the alternate location Mailbox-B; Item from "Drafts" folder of Mailbox-A will be restored to the "Drafts" folder of the alternate location Mailbox-B.

2. If you are trying to restore item(s) from several mailboxes to an alternate location mailbox, AhsayOBM will restore the item(s) to their respective destination folder(s)

in alternate location mailbox with the same name of the original folder(s).

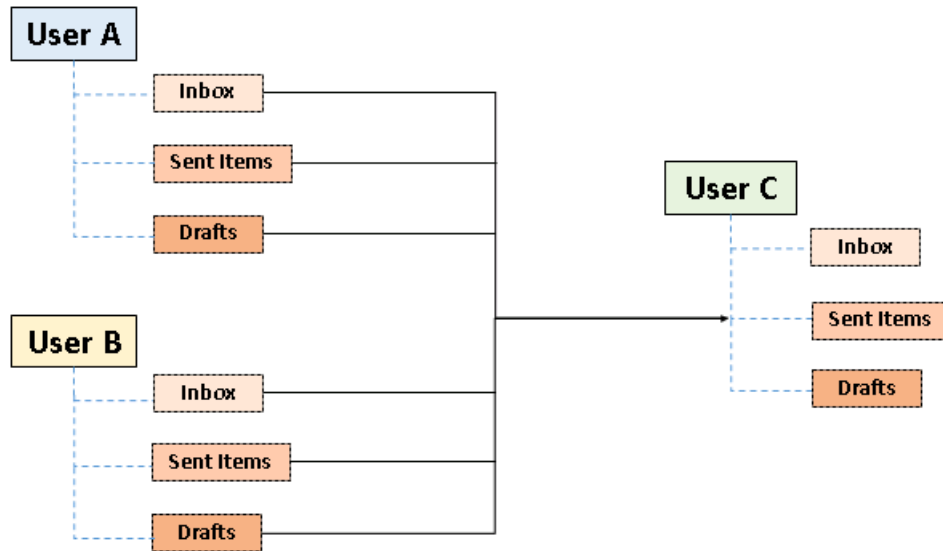

Example: Item from “Inbox” folder of Mailbox-A and Mailbox-B will be restored to the “Inbox” folder of the alternate location Mailbox-C.

3. Restore of mailbox items or public folder items is only supported if the according mailbox or public folder exists.
4. The restore process cannot create a mail item under the user’s Exchange root folder, it can only restore to the supported folders listed in [Chapter 2.2](#).
5. Only Alternate Location is supported for restoring mailbox items to another domain.
6. Restore of mailbox item(s) in public folder to an alternate location mailbox is not supported.

Example: Restore of mailbox item(s) in public folder from Mailbox-A to alternate location Mailbox-B is not supported.

7. If you are trying to restore the mailbox item to a destination mailbox which has a different language setting than the original mailbox, AhsayOBM will restore mailbox item(s) to their respective destination folder based on the translation listed below.

For folders such as ‘Calendar’ or ‘Notes’, a new folder ‘Calendar’ or ‘Notes’ will be created.

Backup source (English)	Action	Destination mailbox with Chinese as default language settings
Inbox	Merge	收件箱
Outbox	Merge	寄件匣
Sent Items	Merge	寄件備份
Deleted Items	Merge	刪除的郵件
Drafts	Merge	草稿
Junk E-Mail	Merge	垃圾電郵
Calendar	Create new folder	Calendar
Notes	Create new folder	Notes

2.4 Best Practices and Recommendations

The following are some best practices or recommendations we strongly recommend you follow before you start any Exchange Server 2013 / 2016 / 2019 Mail Level backup and restore.

- ▶ Mail Level Backup must be utilized in conjunction with Database Level Backup to fully protect an Exchange Server.
- ▶ Active Directory server should be protected by regular full Window System Backup at least once every two weeks.
- ▶ For AhsayOBM installed on Exchange Server, enable scheduled backup jobs when system activity is low to achieve the best possible performance.
- ▶ The remote backup machine should be on the same LAN as the MS Exchange server for optimal backup and restore performance.
- ▶ It is highly recommended to set the temporary directory folder to another location with sufficient free disk space other than Drive C: (e.g. Drive E:).
- ▶ To provide maximum data protection and flexible restore options, it is recommended to configure:
 - At least one offsite or cloud destination
 - At least one local destination for fast recovery
- ▶ Perform test restores periodically to ensure your backup is set up and performed properly. Performing recovery test can also help identify potential issues or gaps in your recovery plan. It's important that you do not try to make the test easier, as the objective of a successful test is not to demonstrate that everything is flawless. There might be flaws identified in the plan throughout the test and it is important to identify those flaws.
- ▶ **Distributed Backup Solution:** For backup of multiple or mass backup sets, to achieve better backup performance and to minimize any unnecessary loading on the Exchange server, please consider deploying AhsayOBM on remote backup machines as distributed backup solution instead of on the MS Exchange server.
- ▶ **Handling Large Number of Mailboxes:** There are two options in backing up large number of mailboxes:
 - Dividing the mailboxes into multiple smaller backup sets
 - Increasing the number of backup threads available

Dividing the mailboxes into multiple smaller backup sets

By default, the MS Exchange 2013 / 2016 / 2019 mail level backup module can back up a maximum of 4 mailboxes concurrently (4 concurrent backup threads), while backing up a maximum of 4 mail items concurrently per mailbox (4 concurrent backup threads). Therefore, each backup set supports a maximum of $4 \times 4 = 16$ backup threads at a time. By splitting up all mailboxes into separate backup sets, the more backup sets, the faster the backup process can achieve.

Example-1: There are 100 mailboxes that need to be backup, you can divide 20 mailboxes into one backup set.

Backup Set Name	Mailbox Number
Backup-Set-1	No.1 -- 20
Backup-Set-2	No.21 -- 40
Backup-Set-3	No.41 -- 60
Backup-Set-4	No.61 -- 80
Backup-Set-5	No.81 -- 100
Note: If there are new mailboxes added, you can create new backup set for the new mailboxes.	

Example-2: There are 100 mailboxes that needs to be backup, you can divide mailboxes into backup sets in alphabetical order.

Backup Set Name	Mailbox Name Start with
Backup-Set-1	A -- E
Backup-Set-2	F -- J
Backup-Set-3	K --O
Backup-Set-4	P -- T
Backup-Set-5	U -- Z
Note: If there are new mailboxes added, you can add the new mailboxes into the original backup set by the corresponding alphabetical order.	

Increasing the number of backup threads available

Apart from splitting up one large Exchange Mail Level backup set into multiple smaller backup sets, another approach is to increase the number of threads available for the backup job.

The number of backup threads is 4 by default. The number of backup threads can be increased (or reduced) by adding the following setting in the AhsayOBM **afc.opt** file located in C:\Program Files\AhsayOBM\afc.opt:

In this example, the number of threads will be increased from 4 to 8.

core.action.BackupExchangeMailCmd.maxConcurrentSubCmd=8

To configure the number of threads, follow the instructions below:

1. Make sure there are no active backup/restore job running.
2. Close the AhsayOBM GUI application.
3. Stop the Ahsay Online Backup Manager services.
4. Go to C:\Program Files\AhsayOBM folder and look for the **afc.opt** file.
5. Open the **afc.opt** file using a text editor such as Notepad or Notepad++.
6. Add the following setting and save the **afc.opt** file.
core.action.BackupExchangeMailCmd.maxConcurrentSubCmd=8
7. Start the Ahsay Online Backup Manager services.

If you choose to use this option, it is strongly recommended that it will used with AhsayOBM deployed on a remote backup machine running on the same LAN as the MS Exchange 2013/2016/2019 server to minimize the load on the Exchange server.

NOTE

The maximum number of threads you can set is entirely dependent on the free resource available (CPU and memory) on each individual MS Exchange server or remote backup machine. In some cases, using more threads may have the opposite effect as it may end up overloading the MS Exchange server or the staging machine.

There are Pros and Cons in choosing an option for handling large number of mailboxes.

Options in Handling Large Number of Mailboxes	Pros	Cons
Dividing the mailboxes into multiple smaller backup sets	Splitting up all mailboxes into separate backup sets will result to faster backup process.	<ul style="list-style-type: none"> ➤ Creation of multiple backup sets is required, and the individual mailboxes have to be manually selected which can be time consuming. ➤ Requires user maintenance of the multiple back sets as the deleted mailboxes need to be unselected and new mailboxes need to be added which can also take time to complete.
Increasing the number of backup threads available	<ul style="list-style-type: none"> ➤ Does not require splitting up large number of mailboxes into multiple back up sets. ➤ Maximum number of concurrent backup threads can be 	The number of threads that can be set will rely on the available resource (CPU and memory) on each individual MS Exchange server or remote backup machine. Thus, using more threads

	configured easily.	may overload the MS Exchange server or the remote backup machine.
--	--------------------	---

- ④ **Periodic Backup Schedule:** The periodic backup schedule should be reviewed regularly to ensure that the interval is sufficient to handle the data volume on the machine. Over time, data usage pattern may change on a production server, i.e. the number of new files created, the number of files which are updated/deleted, and new users may be added etc.

Consider the following key points to efficiently handle backup sets with periodic backup schedule.

- ⦿ Hardware – to achieve optimal performance, compatible hardware requirements is a must. Ensure you have the backup machine's appropriate hardware specifications to accommodate frequency of backups,
 - so that the data is always backed up within the periodic backup interval
 - so that the backup frequency does not affect the performance of the production server
- ⦿ Network – make sure to have enough network bandwidth to accommodate the volume of data within the backup interval.
- ⦿ Retention Policy – also make sure to consider the retention policy settings and retention area storage management which can grow because of the changes in the backup data for each backup job.

3 Overview of MS Exchange Mail Level Backup Process

The following steps are performed during an Exchange Mail Level backup job. For an overview of the detailed process for Steps 3, 5, 10, and 12, refer to the following chapters.

- [Periodic Data Integrity Check \(PDIC\) Process \(Step 3\)](#)
- [Backup Set Index Handling Process](#)
 - [Start Backup Job \(Step 5\)](#)
 - [Completed Backup Job \(Step 12\)](#)
- [Data Validation Check \(Step 10\)](#)

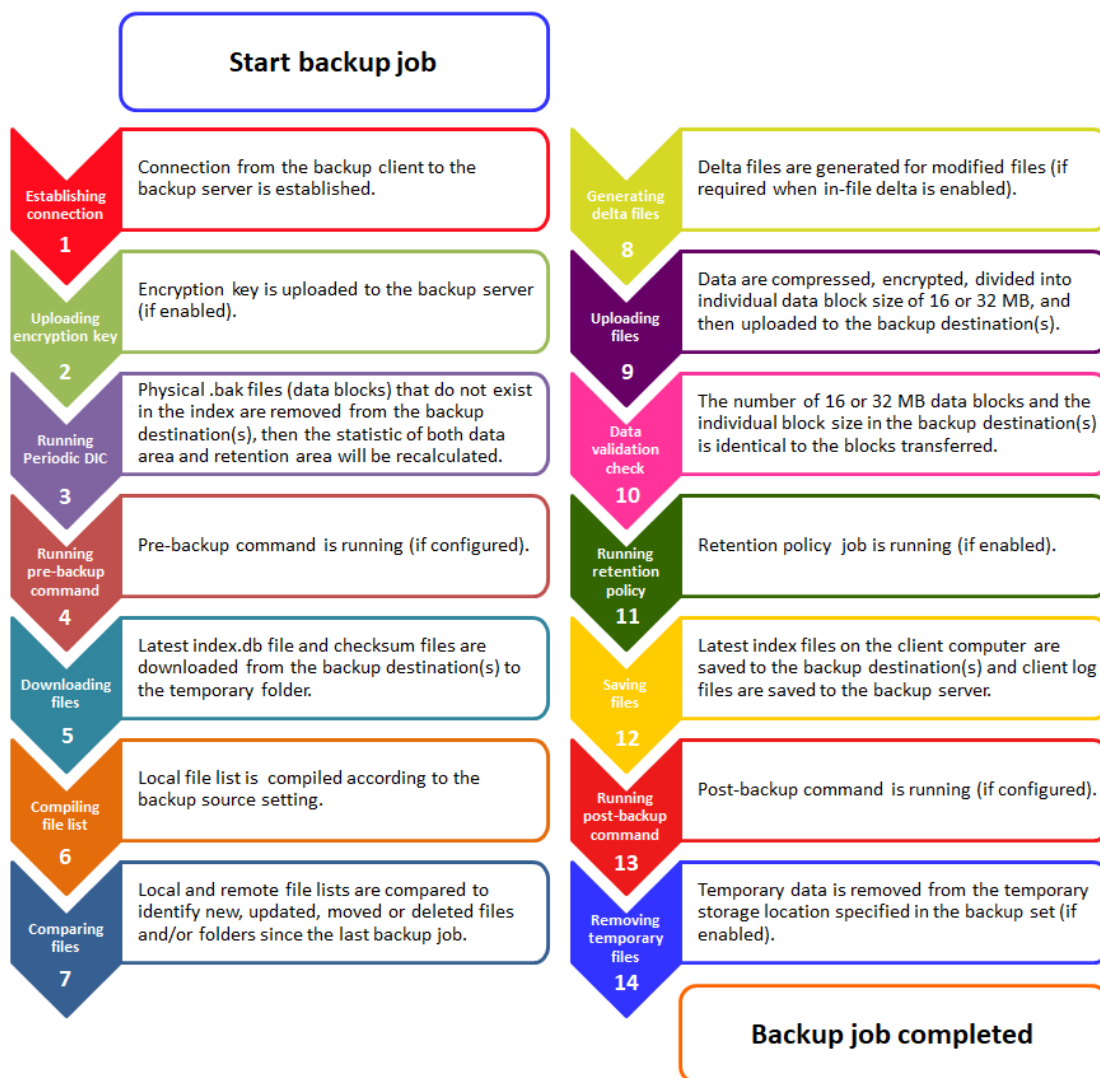

3.1 Periodic Data Integrity Check (PDIC) Process

For AhsayOBM v8.3.6.0 (or above), the PDIC will run on the first backup job that falls on the corresponding day of the week from **Monday to Friday**.

To minimize the impact of the potential load of large number of PDIC jobs running at the same time on the AhsayCBS server, the schedule of a PDIC job for each backup set is automatically determined by the result of the following formula:

$$PDIC\ schedule = \%BackupSetID\% \bmod 5$$

or

$$\%BackupSetID\% \bmod 5$$

The calculated **result** will map to the corresponding day of the week (i.e., from Monday to Friday).

0	Monday
1	Tuesday
2	Wednesday
3	Thursday
4	Friday

NOTE: The PDIC schedule cannot be changed.

Example:

Backup set ID: 1594627447932

Calculation: $1594627447932 \bmod 5 = 2$

2	Wednesday
---	-----------

In this example:

- the PDIC will run on the first backup job that falls on Wednesday; or
- if there is no active backup job(s) running from Monday to Friday, then the PDIC will run on the next available backup job.

NOTE

Although according to the PDIC formula for determining the schedule is $\%BackupSetID\% \bmod 5$, this schedule only applies if the previous PDIC job was actually run more than 7 days prior.

Under certain conditions, the PDIC may not run strictly according to this formula. For example:

1. If AhsayOBM was upgraded to v8.5 (or above) from an older version v6, v7, or pre-8.3.6.0 version. In this case, the PDIC job will run on the first backup job after upgrade.
2. If backup jobs for a backup set are not run on a regular daily backup schedule (for example: on a weekly or monthly schedule), then the PDIC job will run if it detects that the previous PDIC job was run more than 7 days ago.

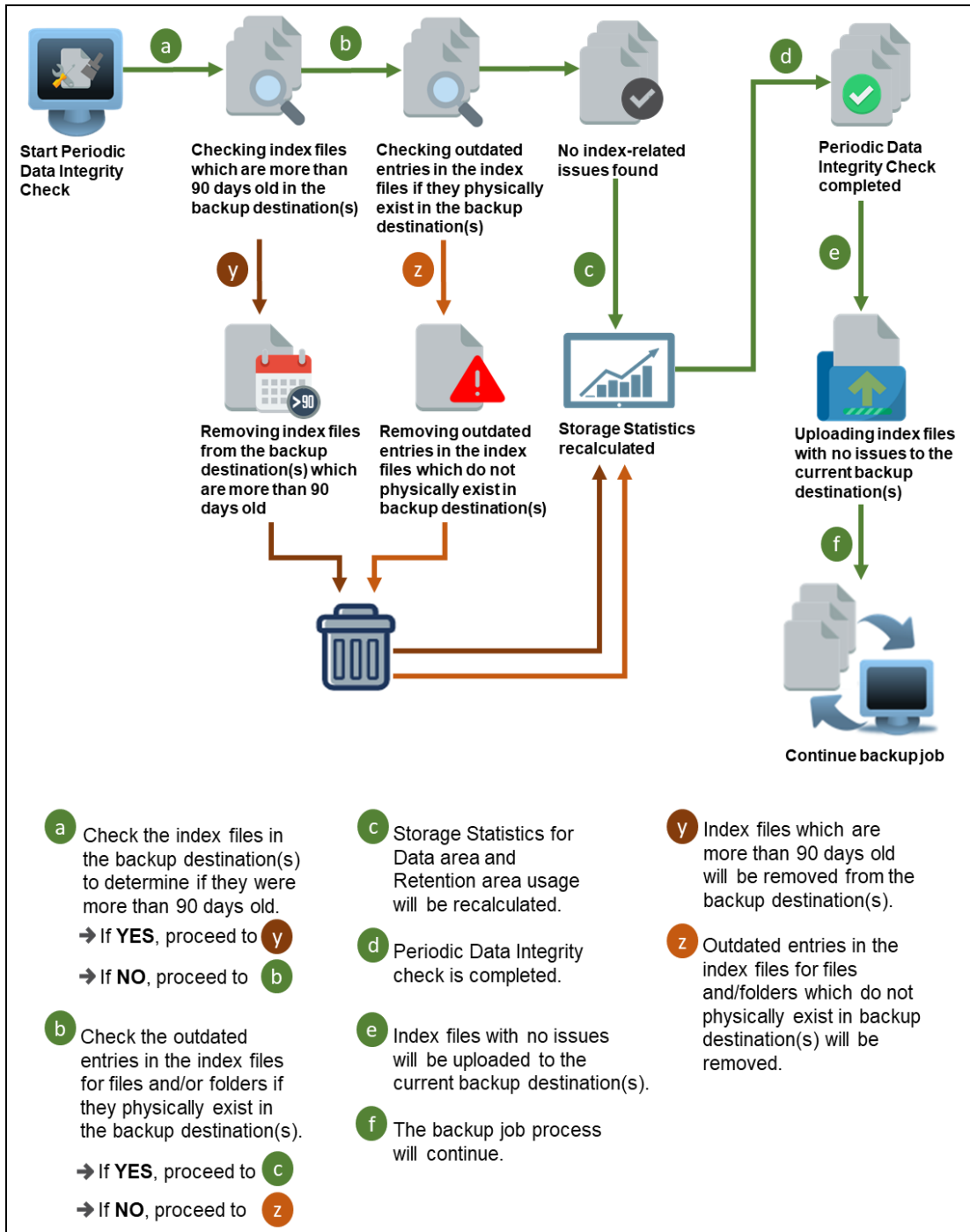

3.2 Backup Set Index Handling Process

To minimize the possibility of index related issues affecting backups, each time index files are downloaded from and uploaded to backup destination(s); the file size, last modified date, and checksum is verified to ensure index file integrity.

3.2.1 Start Backup Job

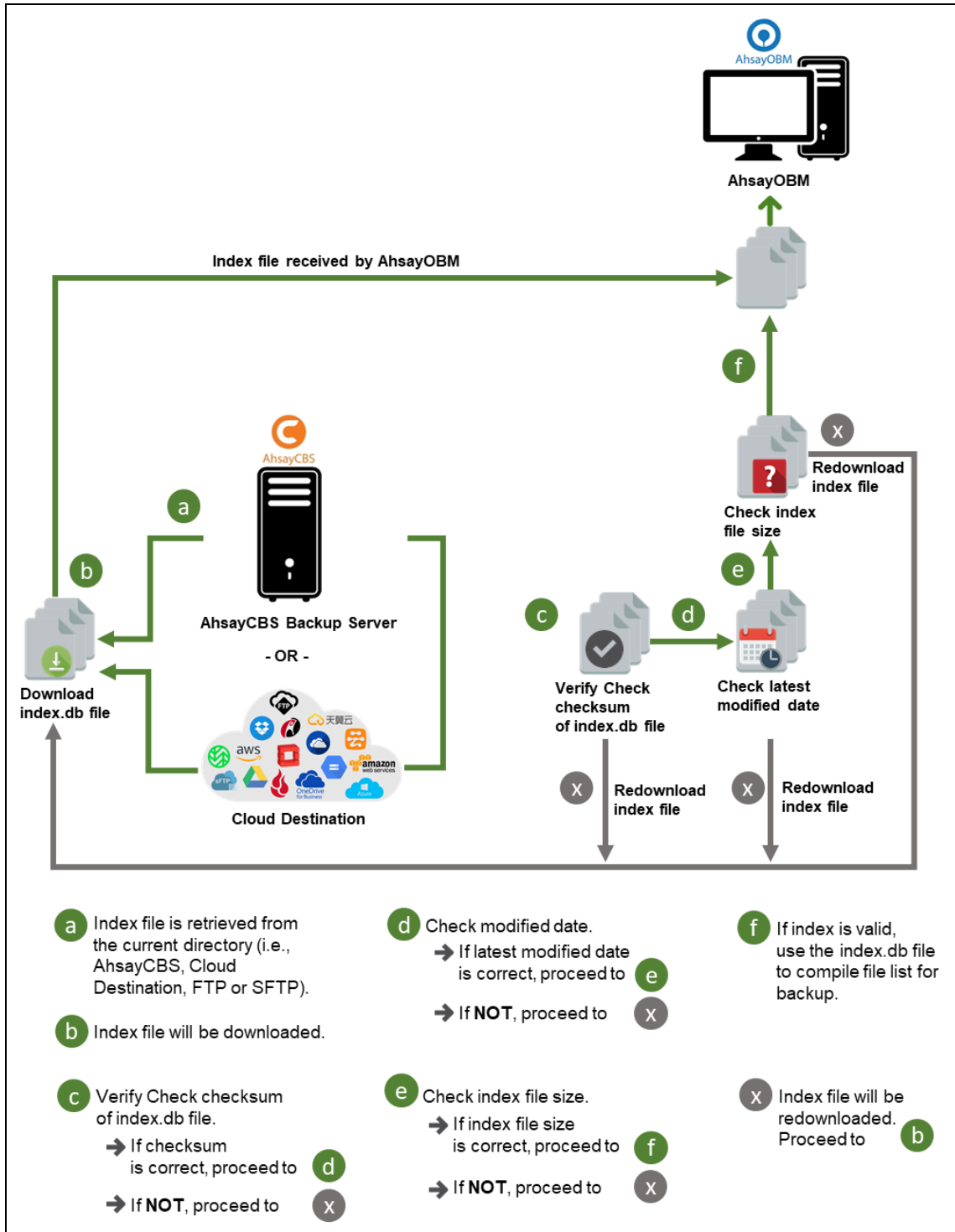

3.2.2 Completed Backup Job

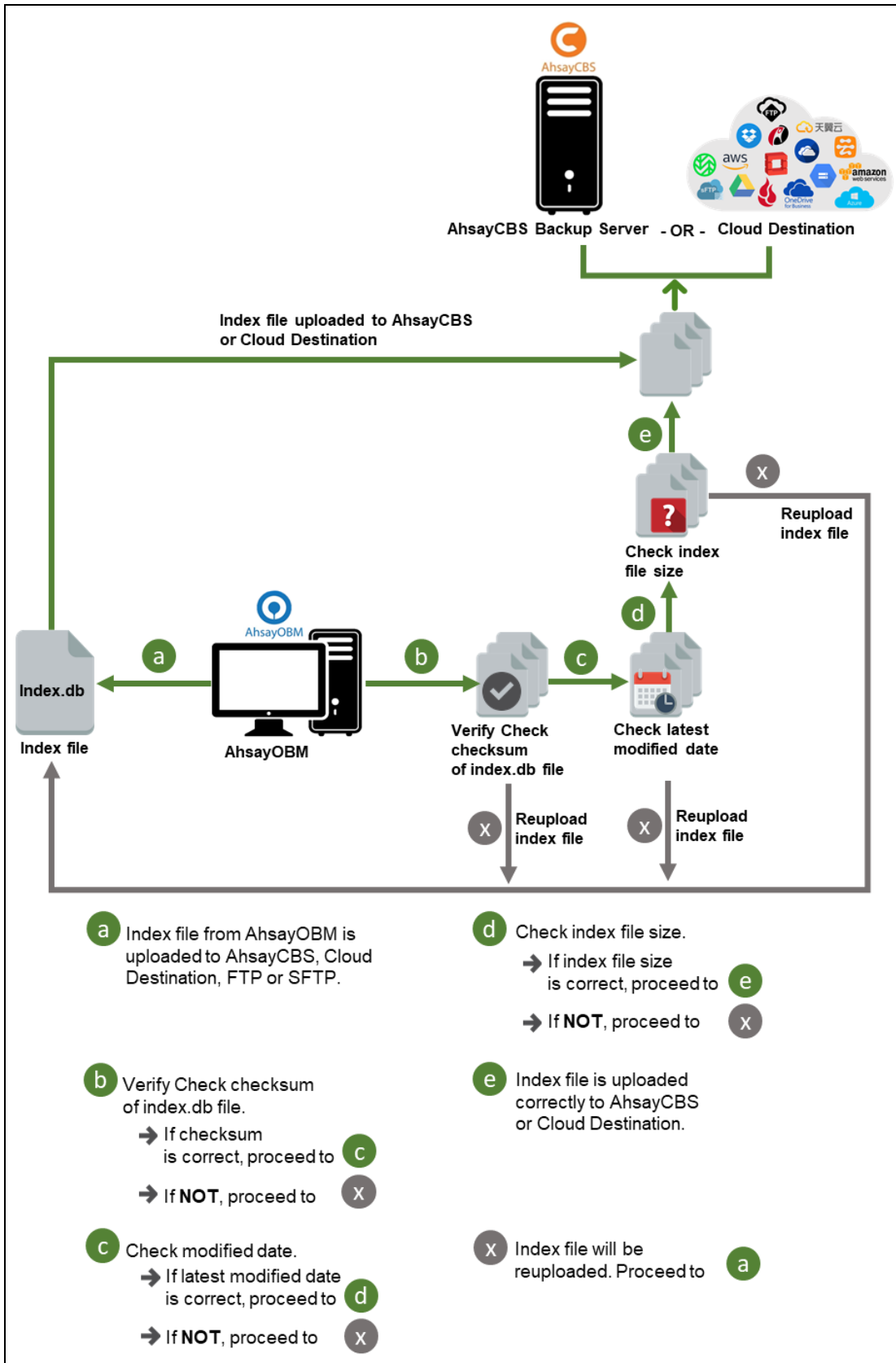

3.3 Data Validation Check Process

As an additional measure to ensure that all files transferred to the backup destination(s) are received and saved correctly, both the number of 16 or 32 MB data block files and the size of each block file are checked again after the files are transferred.

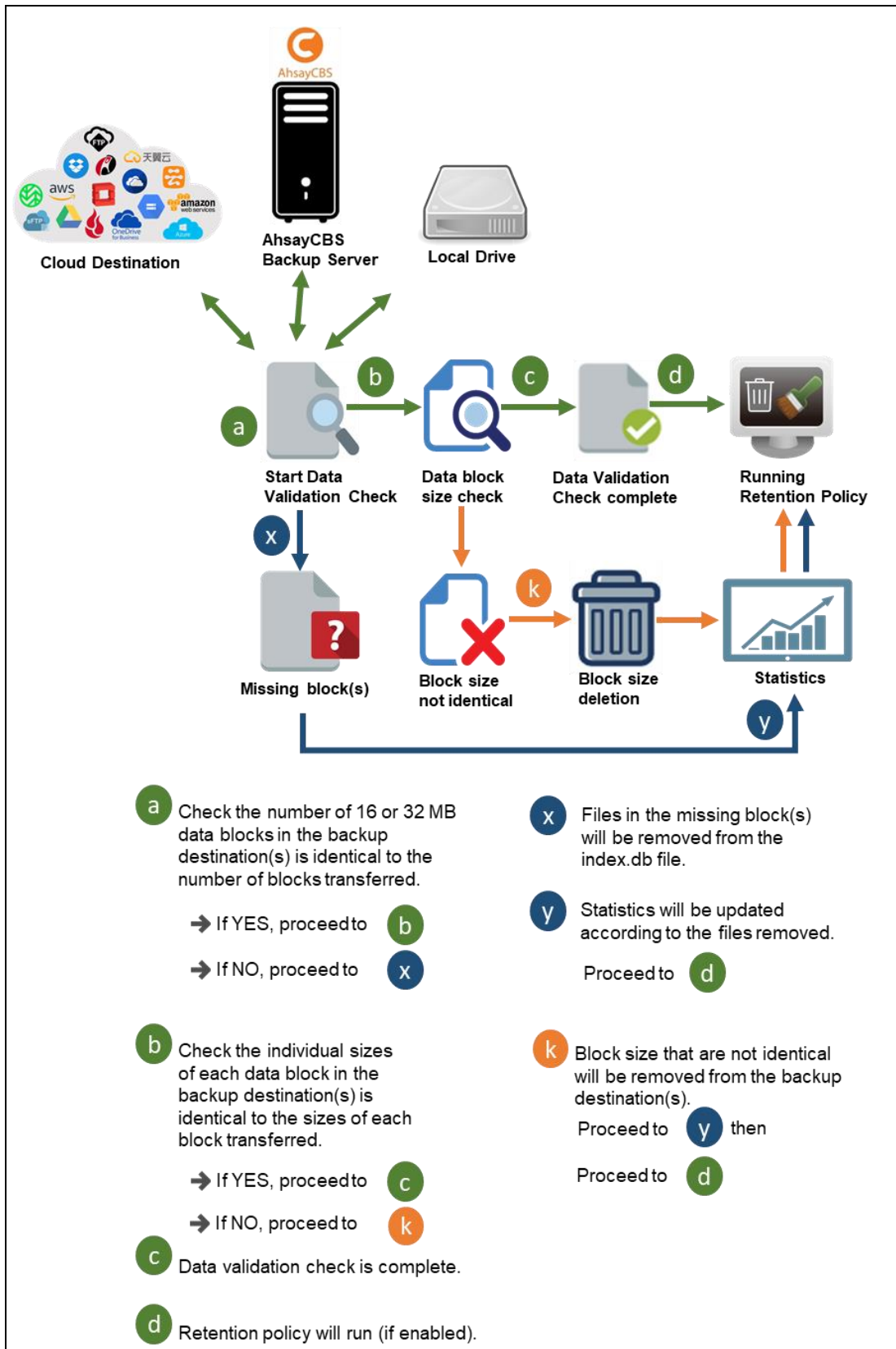

4 Logging in to AhsayOBM

Starting with AhsayOBM v8.5.0.0, there are several login scenarios depending on the setting of the account you are using. The different scenarios will be discussed below:

- [Login without 2FA](#)
- [Login with 2FA using authenticator app](#)
- [Login with 2FA using Twilio](#)

4.1 Login to AhsayOBM without 2FA

1. A shortcut icon of AhsayOBM should have been created on your Windows desktop after installation. Double click the icon to launch the application.

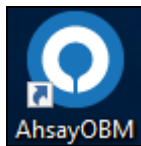

2. Enter the **Login name** and **Password** of your AhsayOBM account provided by your backup service provider, then click **OK** to login.

A screenshot of the AhsayOBM login dialog box. The dialog is dark blue with a white border. It features the AhsayOBM logo and name at the top left. Below the logo, the word 'Login' is displayed. There are two input fields: 'Login name' and 'Password'. Below the 'Password' field, there is a checkbox labeled 'Save password' and a link labeled 'Forgot password'. At the bottom left, there is a link labeled 'Show advanced option'. At the bottom right, there is an 'OK' button. In the top right corner of the dialog, there is a language dropdown menu set to 'English'.

3. After successful login, the following screen will appear.

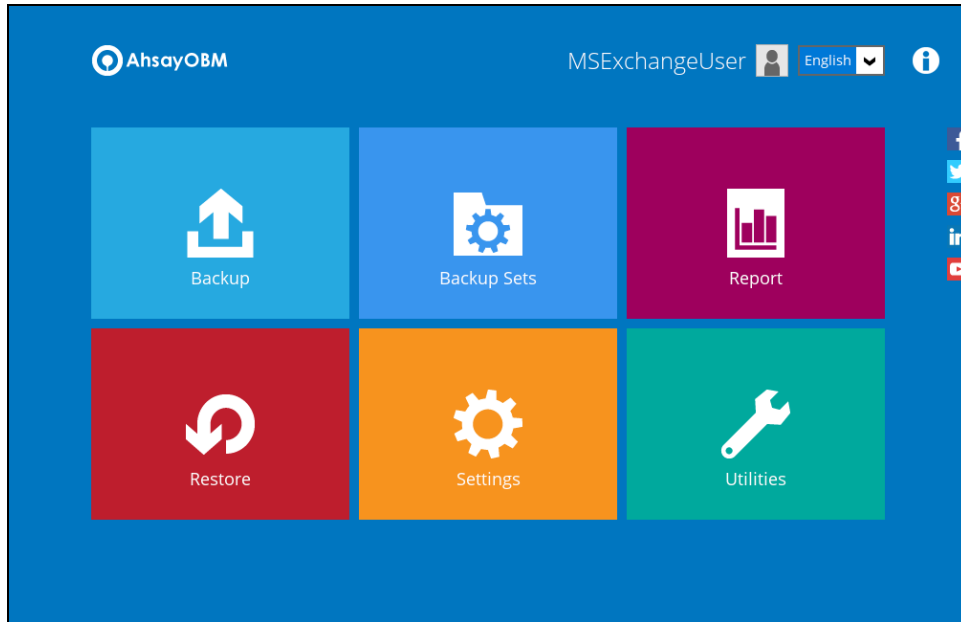

4.2 Login with 2FA using authenticator app

1. A shortcut icon of AhsayOBM should have been created on your Windows desktop after installation. Double click the icon to launch the application.

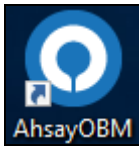

2. Enter the **Login name** and **Password** of your AhsayOBM account provided by your backup service provider, then click **OK** to login.

The image shows the AhsayOBM login screen. It has a blue background with a geometric pattern. In the top right corner, there is a language dropdown menu set to 'English'. The main content is a dark blue login form with the AhsayOBM logo and the text 'Login'. Below the logo, there are two input fields: 'Login name' and 'Password'. There is a checkbox for 'Save password' and a link for 'Forgot password'. At the bottom of the form, there is a 'Show advanced option' link and an 'OK' button.

3. One of the two authentication methods will be displayed to continue with the login:
 - [Push Notification and TOTP when using Ahsay Mobile app](#)
 - [TOTP only](#)
- If **Ahsay Mobile app** was configured to use Push Notification and TOTP then there are two 2FA modes that can be used:

- Push Notification (default)

Push notification is the default 2FA mode. Accept the login request on Ahsay Mobile to complete the login.

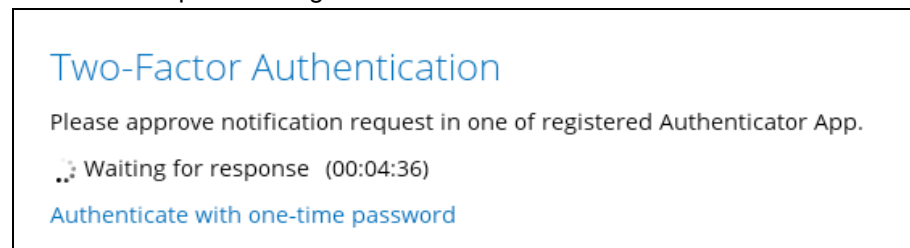

Example of the login request sent to the Ahsay Mobile app.

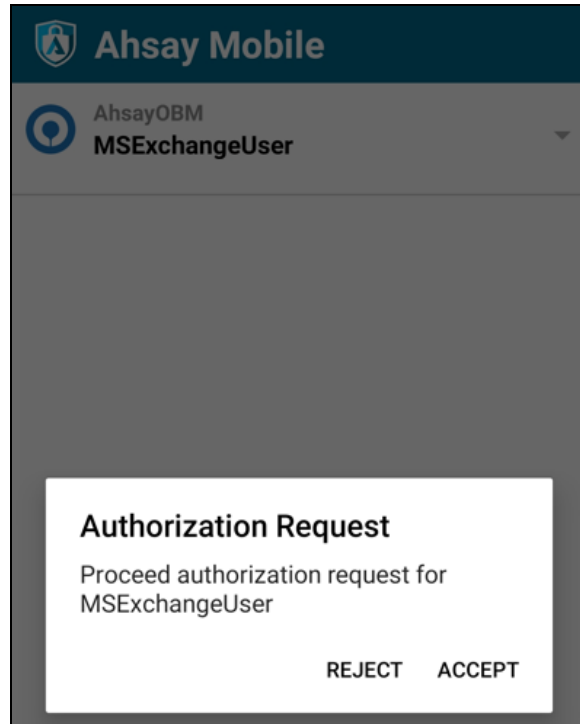

- TOTP

However, if push notification is not working or you prefer to use one-time passcode, click the [Authenticate with one-time password](#) link, then input the one-time passcode generated by Ahsay Mobile to complete the login.

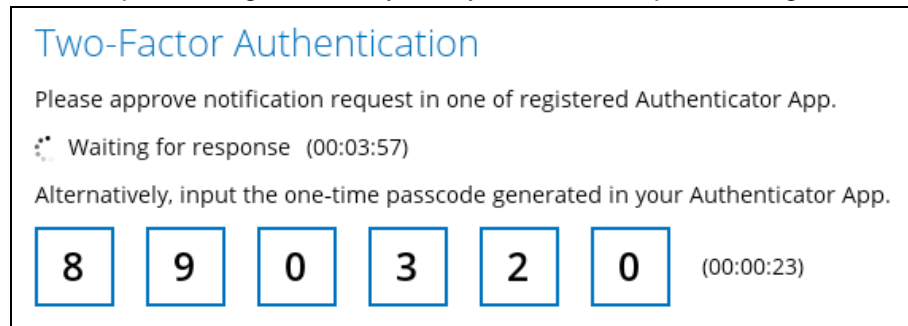

Example of the one-time passcode generated in Ahsay Mobile.

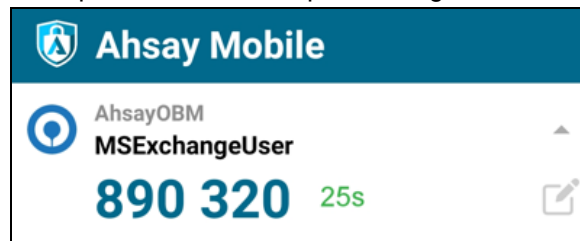

- TOTP only

Enter the one-time passcode generated by the authenticator app to complete the login.

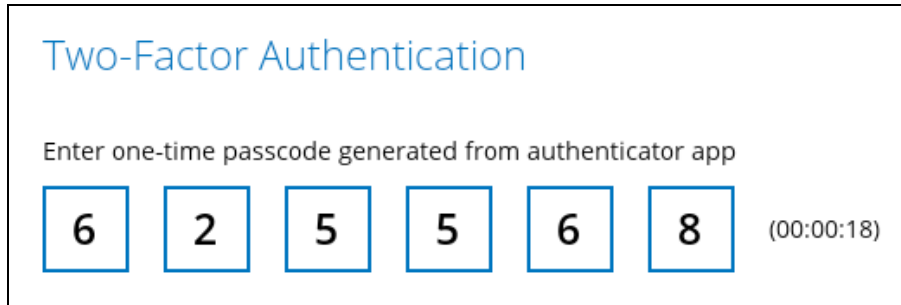

Example of the one-time passcode generated in the third party authenticator app Microsoft Authenticator.

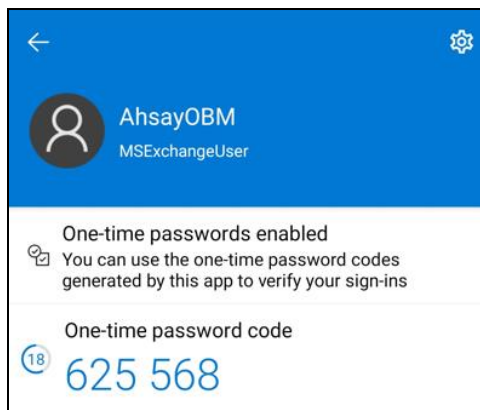

4. After successful login, the following screen will appear.

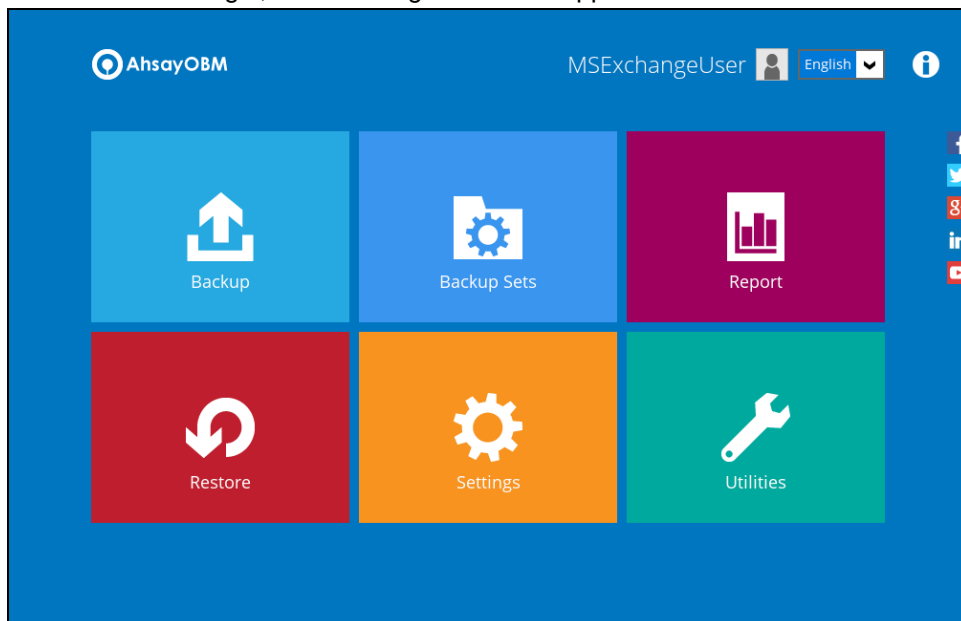

NOTE

If you have trouble logging in using the authenticator app please refer to Chapter 9 of the [AhsayOBM Quick Start Guide for Windows](#) for more information.

4.3 Login with 2FA using Twilio

1. A shortcut icon of AhsayOBM should have been created on your Windows desktop after installation. Double click the icon to launch the application.

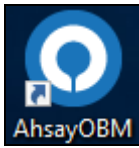

2. Enter the **Login name** and **Password** of your AhsayOBM account provided by your backup service provider, then click **OK** to login.

The image shows the AhsayOBM login dialog box. It has a dark blue background with a lighter blue geometric pattern. At the top right, there is a language dropdown menu set to 'English'. The main content area is a dark blue rectangle with the AhsayOBM logo and the text 'Login'. Below this, there are two white input fields for 'Login name' and 'Password'. There is a checkbox for 'Save password' and a link for 'Forgot password'. At the bottom left, there is a link for 'Show advanced option', and at the bottom right, there is an 'OK' button.

3. Select your phone number.

The image shows the Two-Factor Authentication dialog box. It has a white background with a blue header and footer. The header contains the text 'Two-Factor Authentication'. Below the header, there is a message: 'Please select phone number to receive passcode via SMS message to continue login.' There are three radio button options, each with a blue telephone icon: 'Austria (+43) - *****6588', 'Philippines (+63) - *****6123', and 'Switzerland (+41) - *****4731'. At the bottom right, there are two buttons: 'Cancel' and 'Help'.

4. Enter the passcode and click **Verify** to login.

Two-Factor Authentication

SMS message with a passcode was already sent to the phone number Philippines (+63) - *****6123
Please enter the passcode to continue login.

EUVS - (00:03:59)

Resend passcode

Verify Cancel Help

5. After successful login, the following screen will appear.

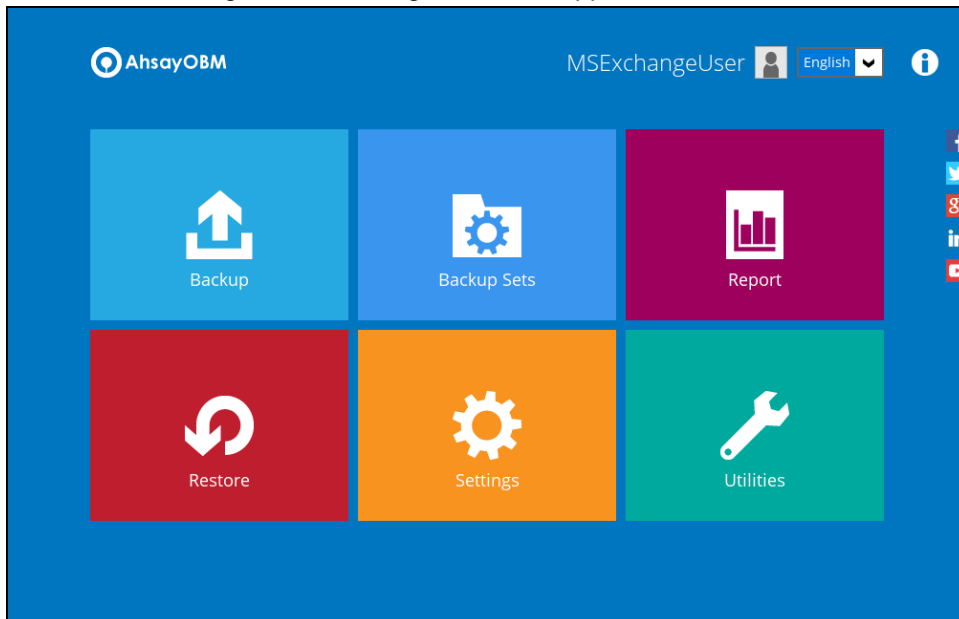

5 On Exchange Server

5.1 Standalone Backup Option

5.1.1 Create Mail Level Backup Set

1. Click the **Backup Sets** icon on the main interface of AhsayOBM.

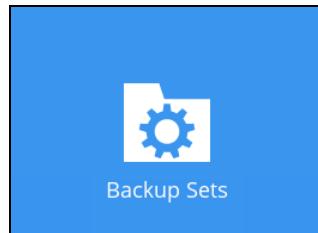

2. Create a new backup set by clicking the "+" icon next to **Add new backup set**.

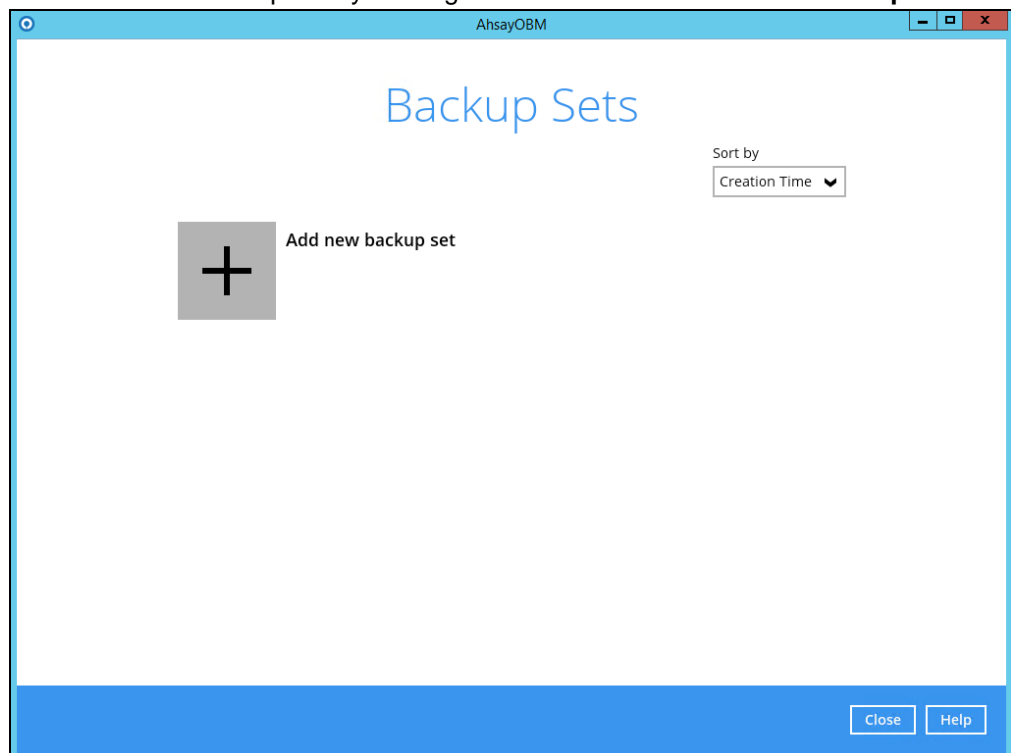

3. Select the Backup set type as **MS Exchange Mail Level Backup**. The system will automatically detect and select the Exchange Server version, make sure the version selected is correct.
 - Name your new backup set.
 - Select from the following version:
 - Microsoft Exchange Server 2013
 - Microsoft Exchange Server 2016
 - Microsoft Exchange Server 2019
 - Microsoft Exchange Server 2013 (DAG)

- Microsoft Exchange Server 2016 (DAG)
- Microsoft Exchange Server 2019 (DAG)

As AhsayOBM is installed directly on the MS Exchange server. The correct MS Exchange version will be automatically selected.

- Enter the hostname of Exchange server.
- Enter the username and password of the Windows user account used for backup.
- Check the “Access the Internet through proxy” if required.
- Click the **Test** button to verify the login details.
- Then click **Next** to proceed.

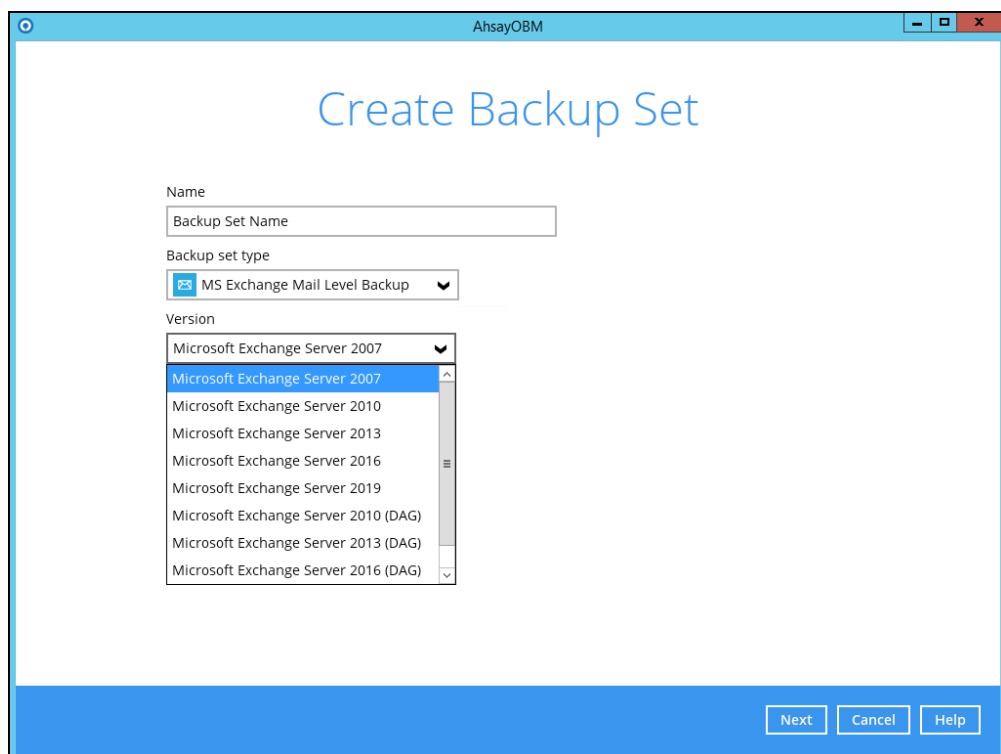

4. In the **Backup Source** menu, select the mailboxes or public folders for backup. Fifty (50) users will be displayed by default. If the MS Exchange Server account consists of more than fifty (50) users or above, click the **show next 50** button to display the next users. You can expand the mailbox or public folder to select which mail folder to back up by clicking the **[+]** button. You can also click **Show mails** to select an individual mail to back up. Once done, click **Next** to proceed.

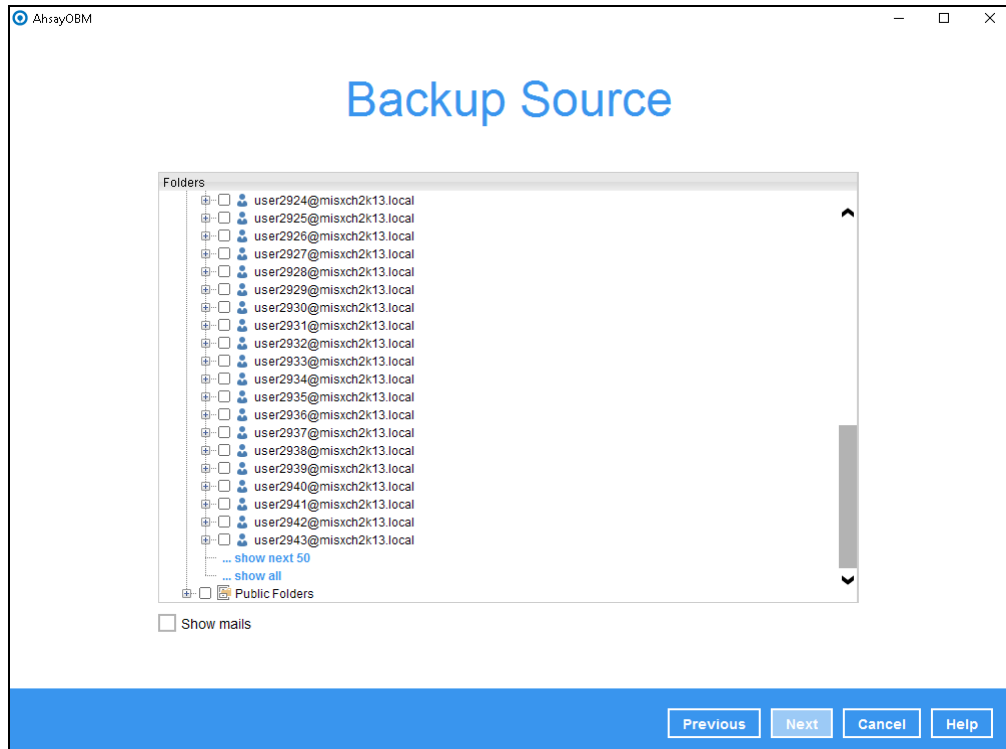

5. In the Schedule menu, you can configure a backup schedule for backup job to run automatically at your specified time interval. By default, the **Run scheduled backup for this backup set** option is disabled. Enable it, then click the “+” icon next to **Add new schedule**. Click **Next** to proceed when you are done setting.

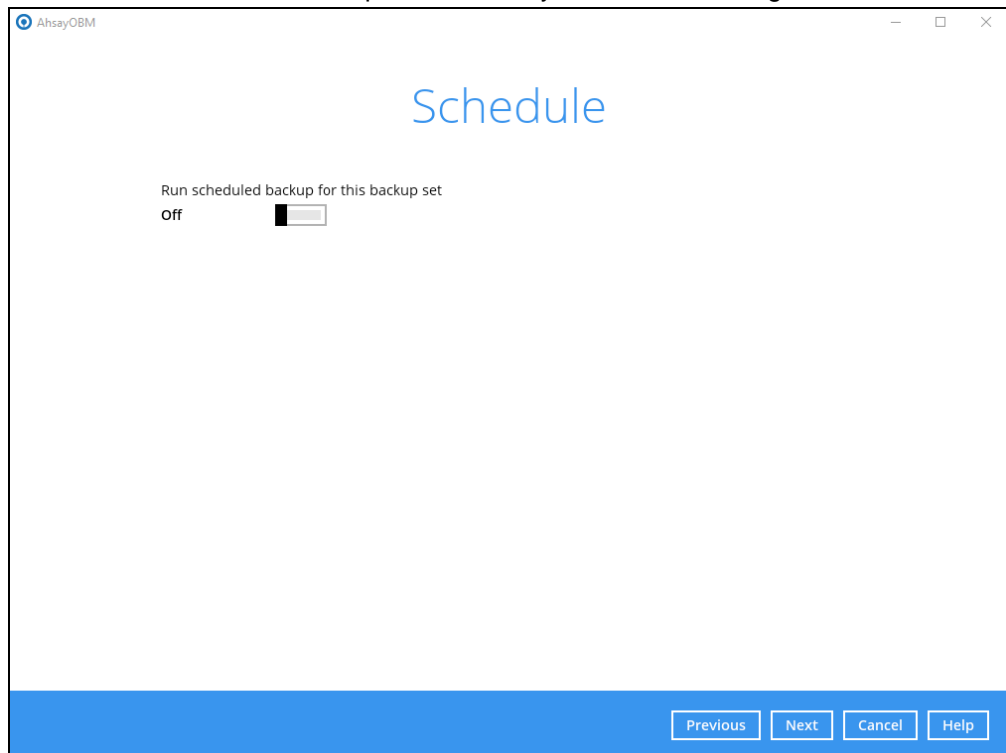

6. In the Destination menu, select a backup destination where the backup mail will be stored. Click the “+” icon next to **Add new storage destination / destination pool**.

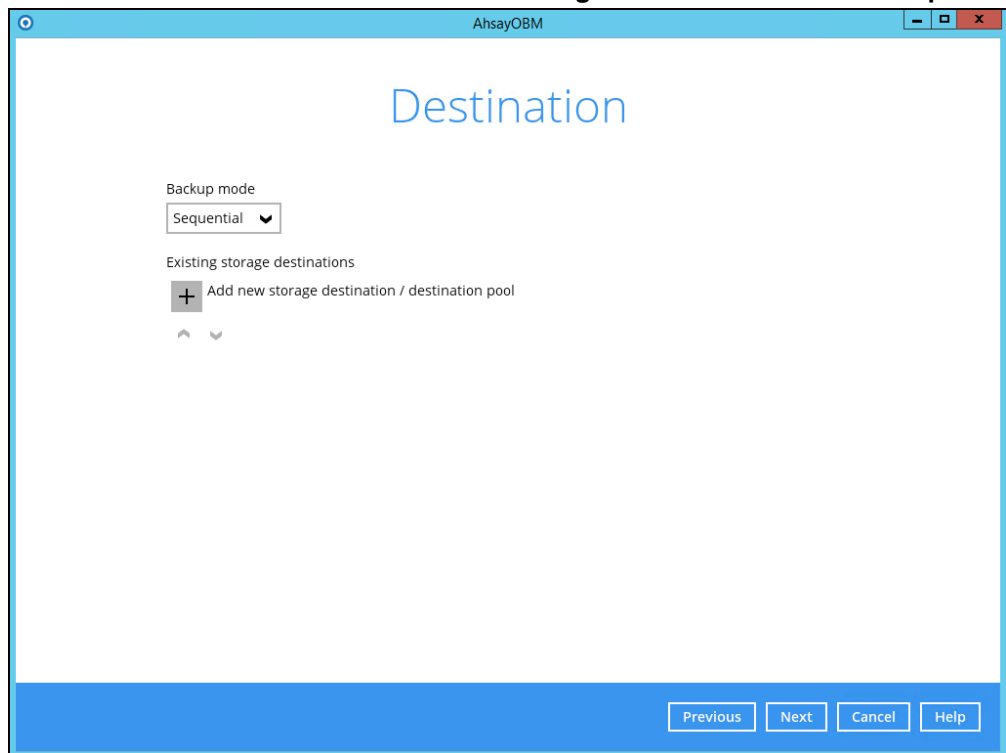

7. Select the destination storage, then click **OK** to proceed.

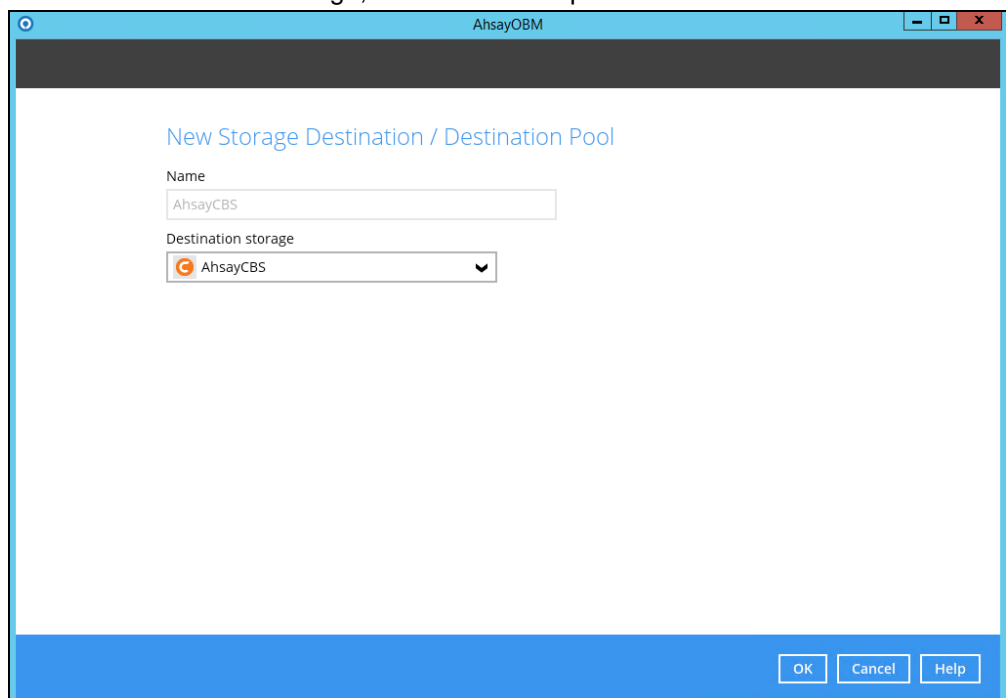

8. Click **Next** on the Destination menu page to proceed.

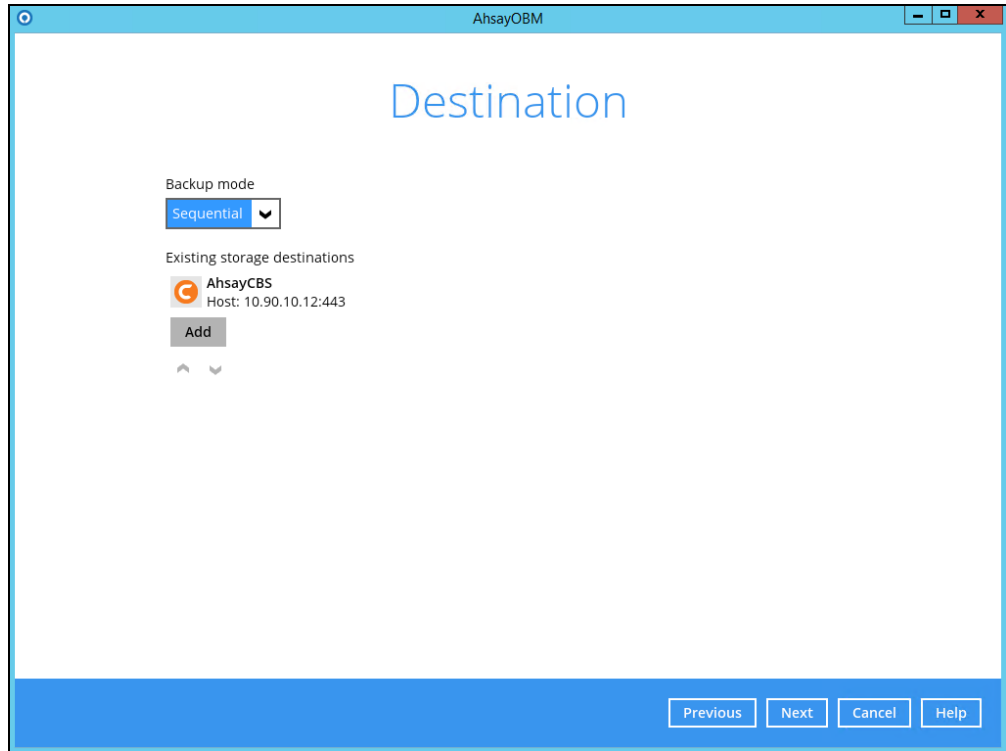

9. In the Encryption window, the default **Encrypt Backup Data** option is enabled with an encryption key preset by the system which provides the most secure protection.

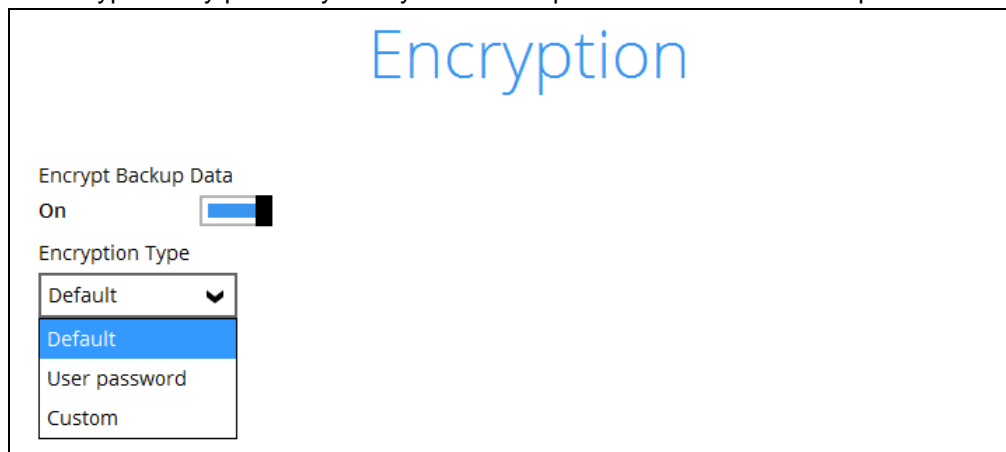

10. You can choose from one of the following three Encryption Type options:
- **Default** – an encryption key with 44 alpha numeric characters will be randomly generated by the system
 - **User password** – the encryption key will be the same as the login password of your AhsayOBM at the time when this backup set is created. Please be reminded that if you change the AhsayOBM login password later, the encryption keys of the backup sets previously created with this encryption type will remain unchanged.

- **Custom** – you can customize your encryption key, where you can set your own algorithm, encryption key, method and key length.

Encryption

Encrypt Backup Data
On

Encryption Type
Custom ▼

Algorithm
AES ▼

Encryption key

Re-enter encryption key

Method
 ECB CBC

Key length
 128-bit 256-bit

NOTE

For best practice on managing your encryption key, refer to the following article: [Best Practices for Managing Encryption Key on AhsayOBM or AhsayACB.](#)

Click **Next** when you are done.

11. If you have enabled the Encryption Key feature in the previous step, the following pop-up window shows, no matter which encryption type you have selected.

Encryption

Encrypt Backup Data
On

Encryption Type
User password ▼

You are advised to write this encryption key down on paper and keep it in a safe place. You will need it when you need to restore your files later. Please confirm that you have done so.

Unmask encryption key

Copy to clipboard Confirm

The pop-up window has the following three options to choose from:

- **Unmask encryption key** – The encryption key is masked by default. Click this option to show the encryption key.

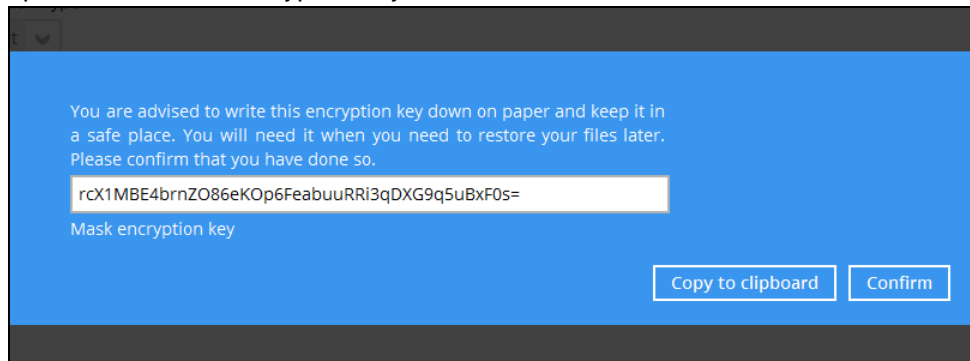

- **Copy to clipboard** – Click to copy the encryption key, then you can paste it in another location of your choice.
- **Confirm** – Click to exit this pop-up window and proceed to the next step

12. Enter the Windows login credentials for user authentication. Click **Next** to proceed. The User name should be entered in the following format "user@hostname", i.e. administrator@ahsay.com

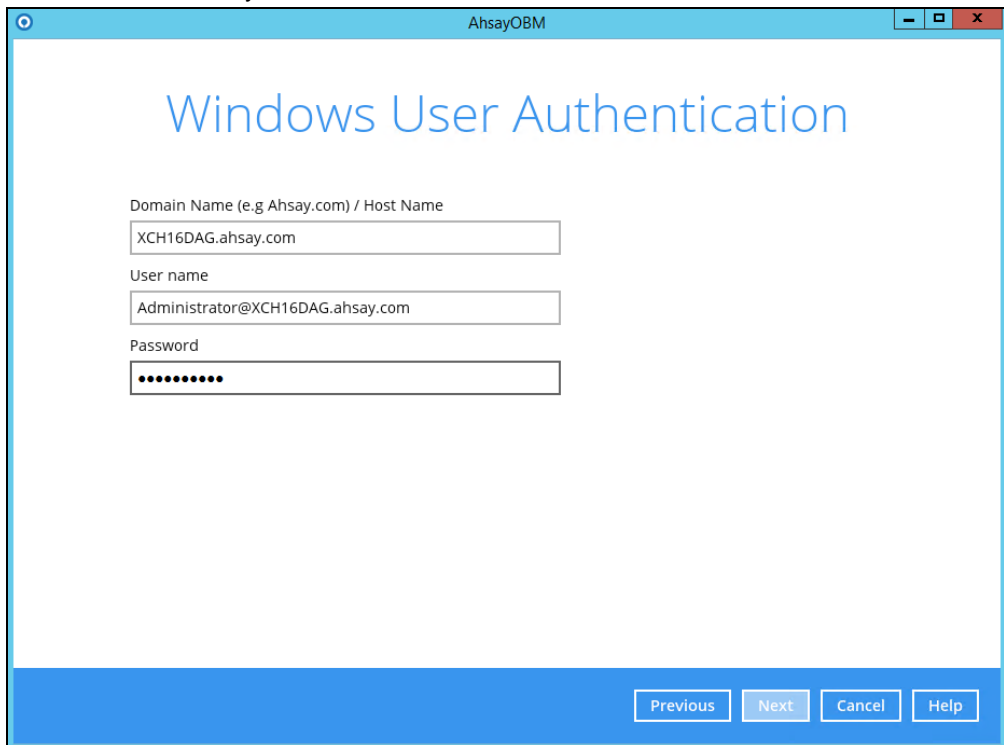

NOTE

The Windows User Authentication interface will show only if scheduled backup is enabled and set successfully.

13. The following screen shows when the new backup set is created successfully.

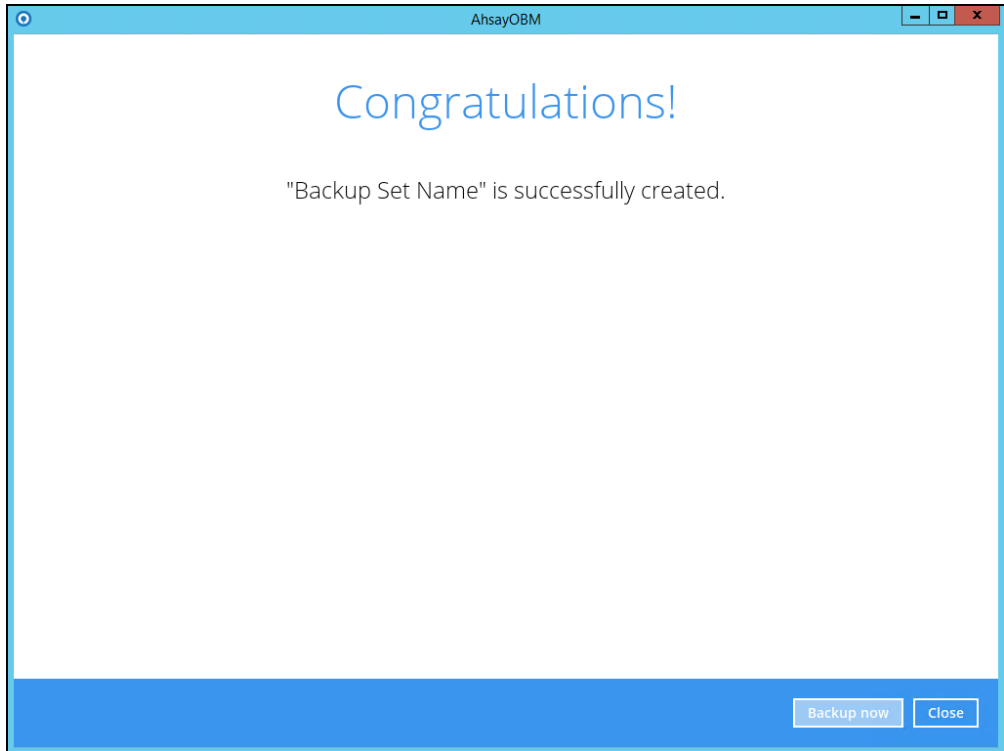

14. Click **Backup now** to start a backup immediately, or you can run a backup job later by following the instructions in [Run Mail Level Backup Job](#).
15. Based on [Best Practices and Recommendations](#), it is highly recommended to set the **temporary directory** to another location other than Drive C: (e.g. Drive E:). To do this, go to **Backup Sets > Others > Temporary Directory** and click the **Change** button to browse for another location.

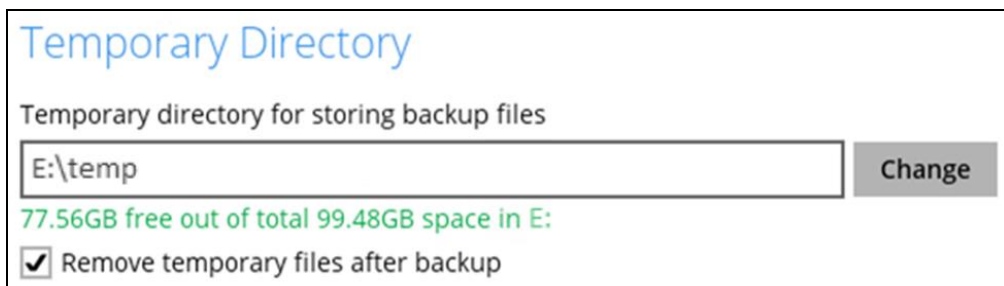

16. Optional: Select your preferred **Compression** type. By default, the compression type is Fast with optimization for local.

Go to **Others > Compressions**, then select from the following:

- No Compression
- Normal
- Fast (Compressed size larger than normal)
- Fast with optimization for local

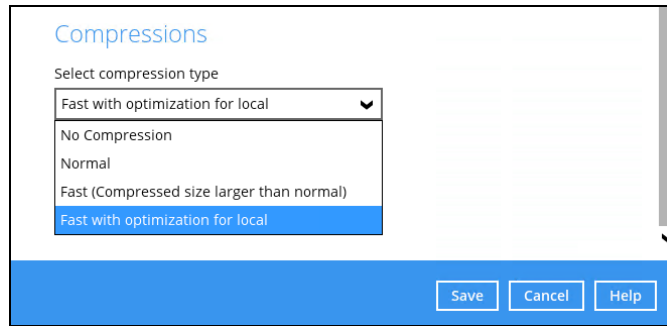

5.1.2 Run Mail Level Backup Job

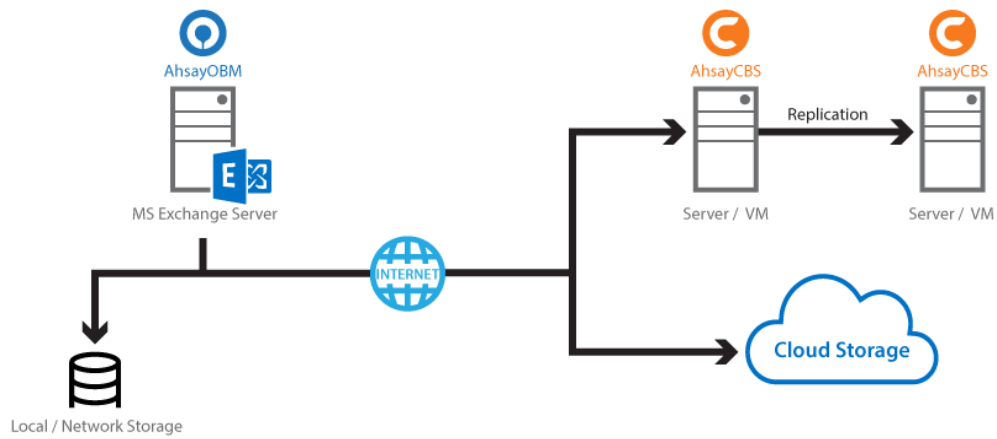

Below are the steps of the backup process.

1. Log in to AhsayOBM.
2. Click the Backup icon on the main interface of AhsayOBM.



3. Select the backup set which you would like to start a backup for.

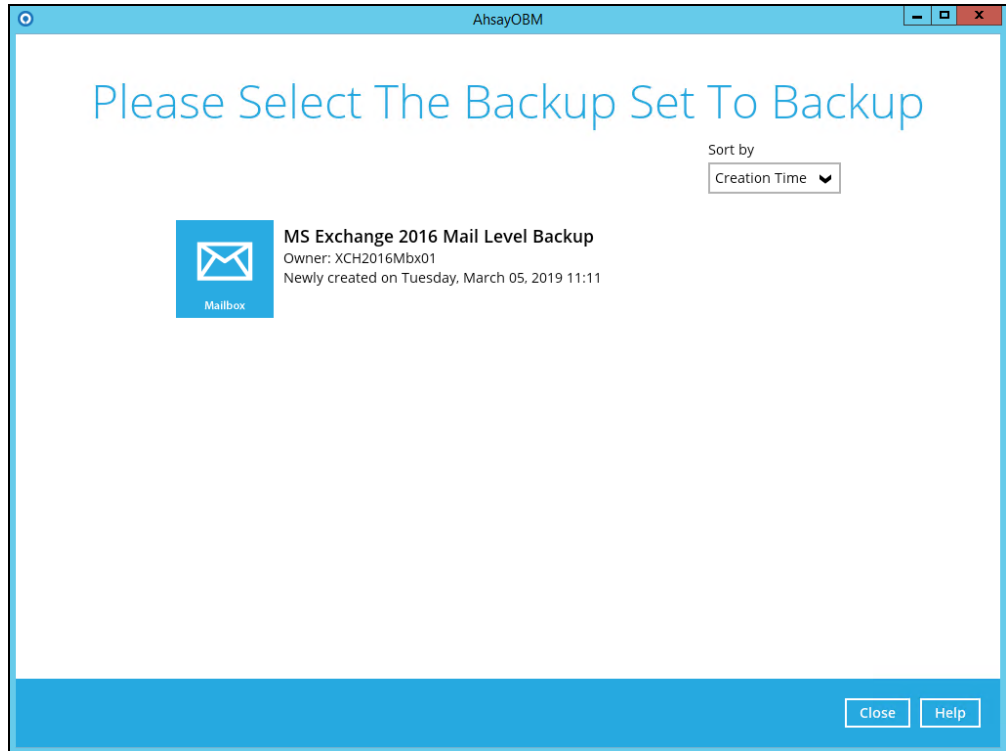

4. If you would like to modify the In-File Delta type, Destinations and Retention Policy settings, click **Show advanced option**.

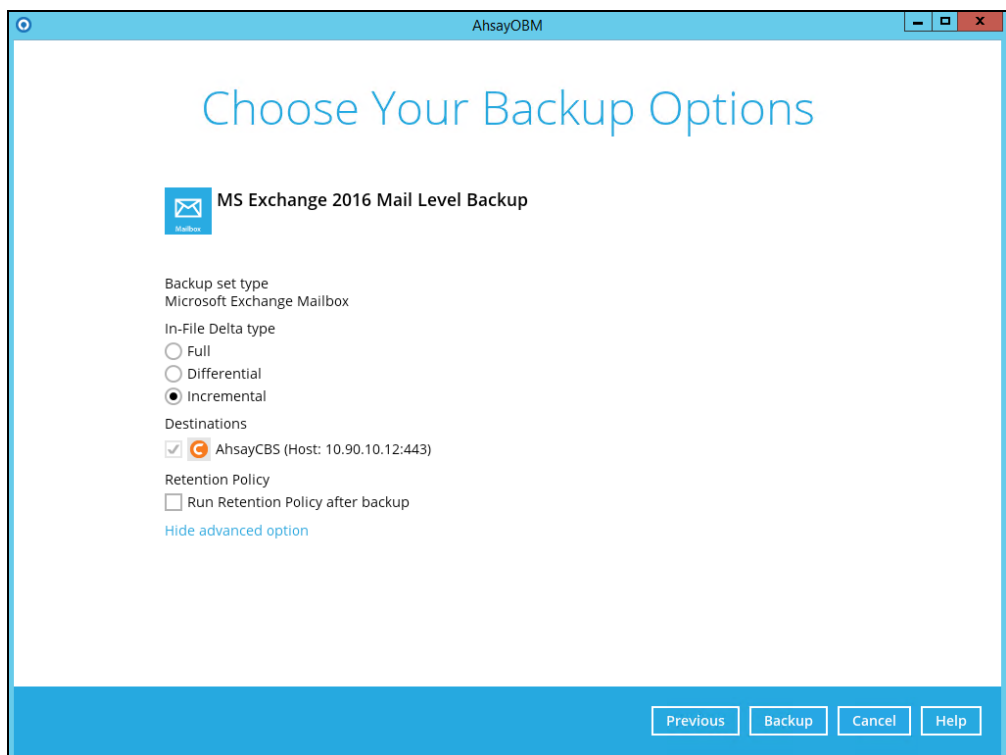
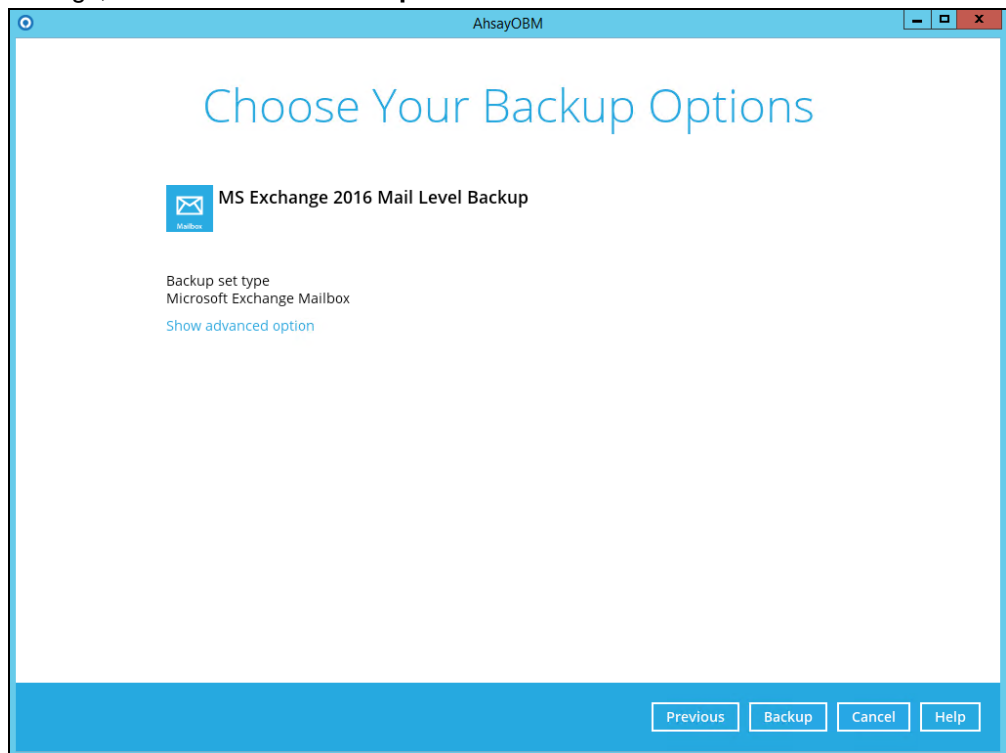

5. Click **Backup** to start the backup.

5.1.3 Restore Mail Level Backup

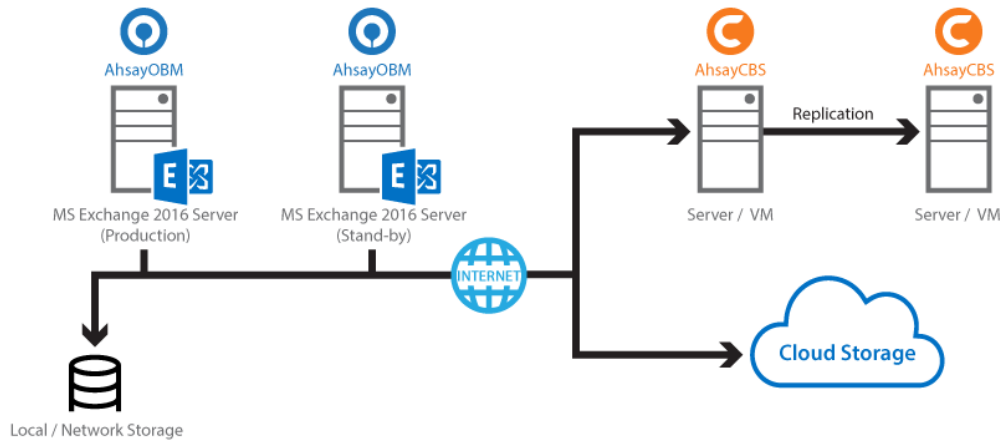

Below are the steps of the restore process.

1. In the AhsayOBM main interface, click the **Restore** icon.

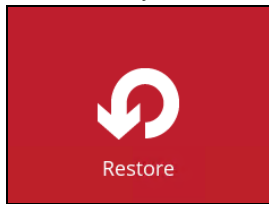

2. Select the backup set that you would like to restore mail from.

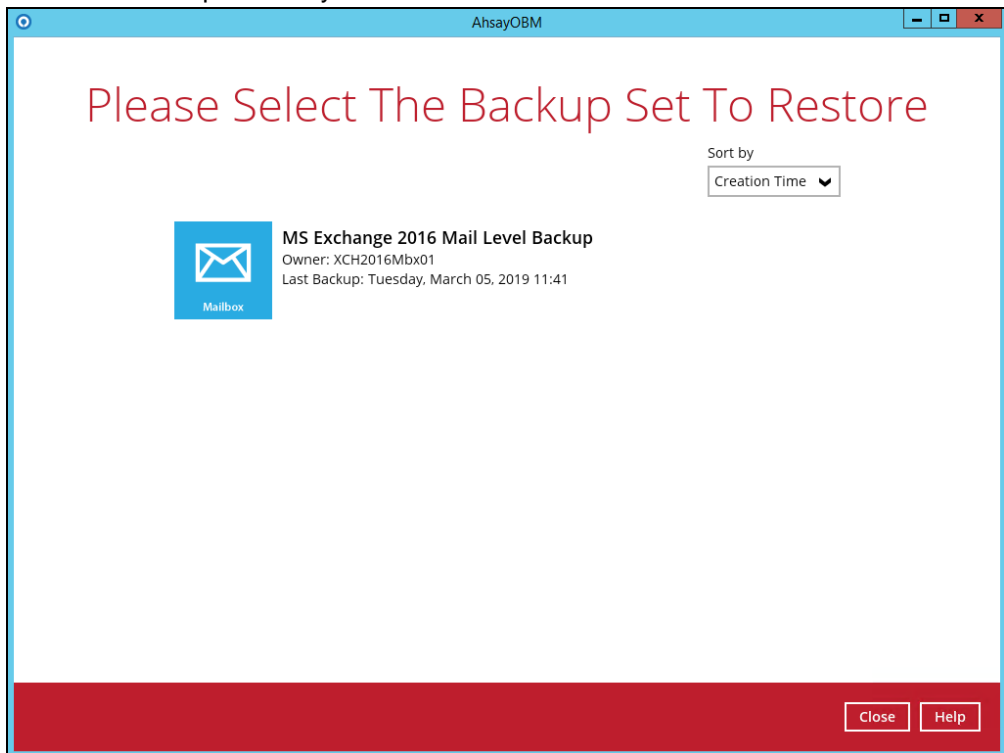

3. Select the backup destination that contains the mail(s) that you would like to restore.

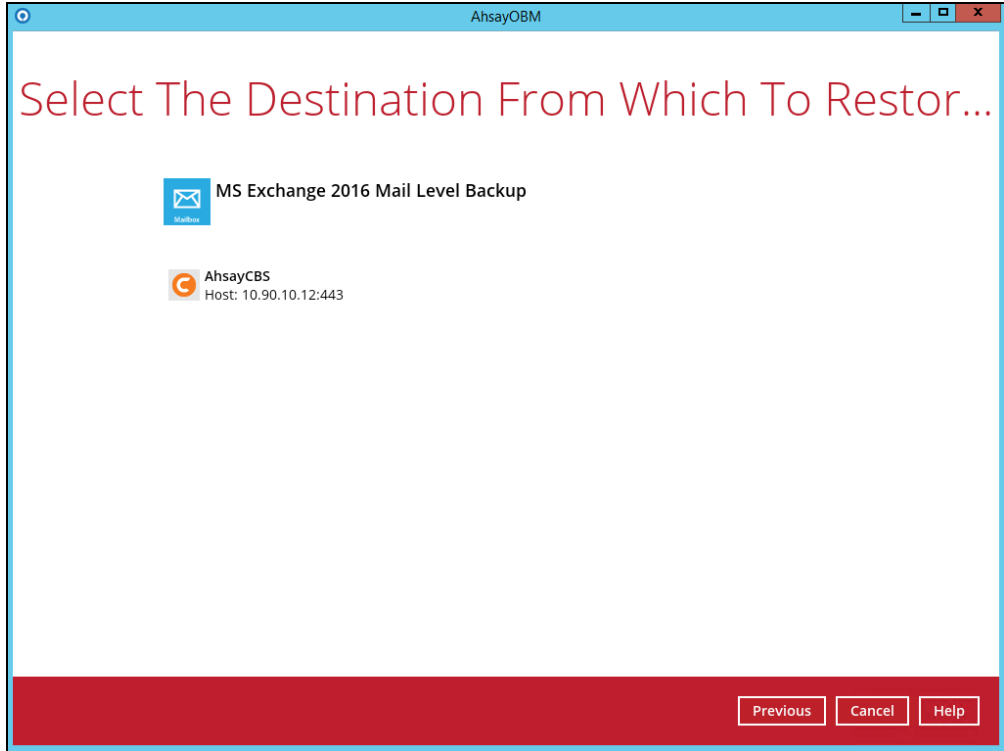

4. Click to expand the menu tree to select which mailbox to restore. You can also select mail item(s) from a specific backup job or all mail items that you have backed up to restore. Click **Next** to proceed.

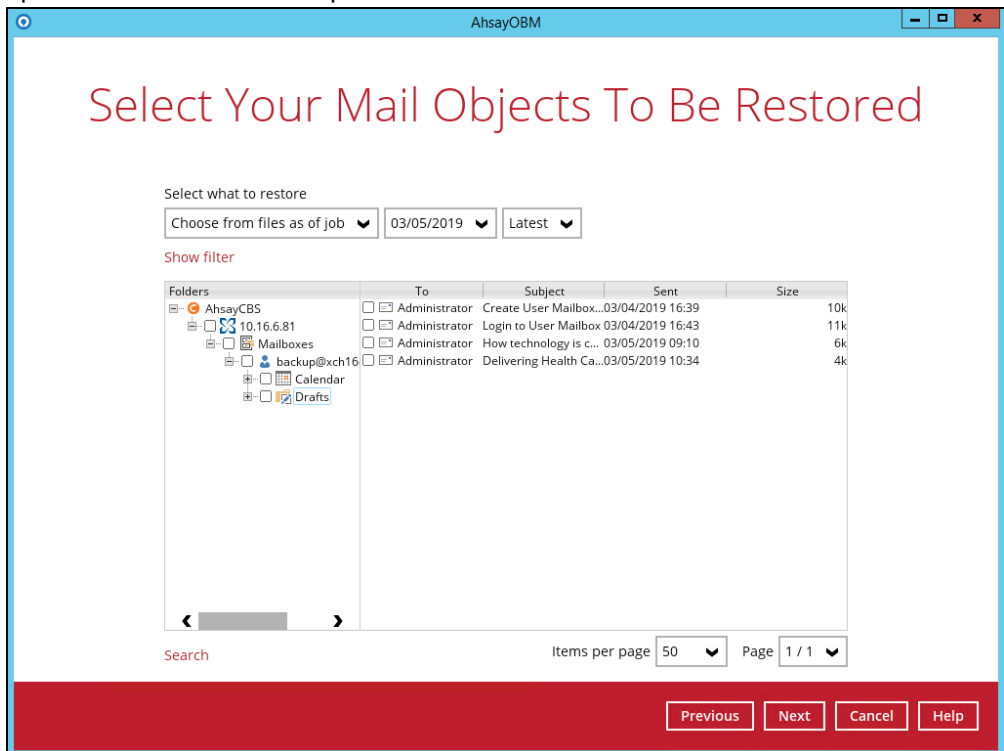

5. Select to restore the mail to their Original location, Alternate location or to an Alternate host.

⦿ **Restore to Original Location**

Select the **Original location** option. If you would like to modify the Verify checksum of in-file delta files setting, click **Show advanced option**. Then press **Next** to proceed.

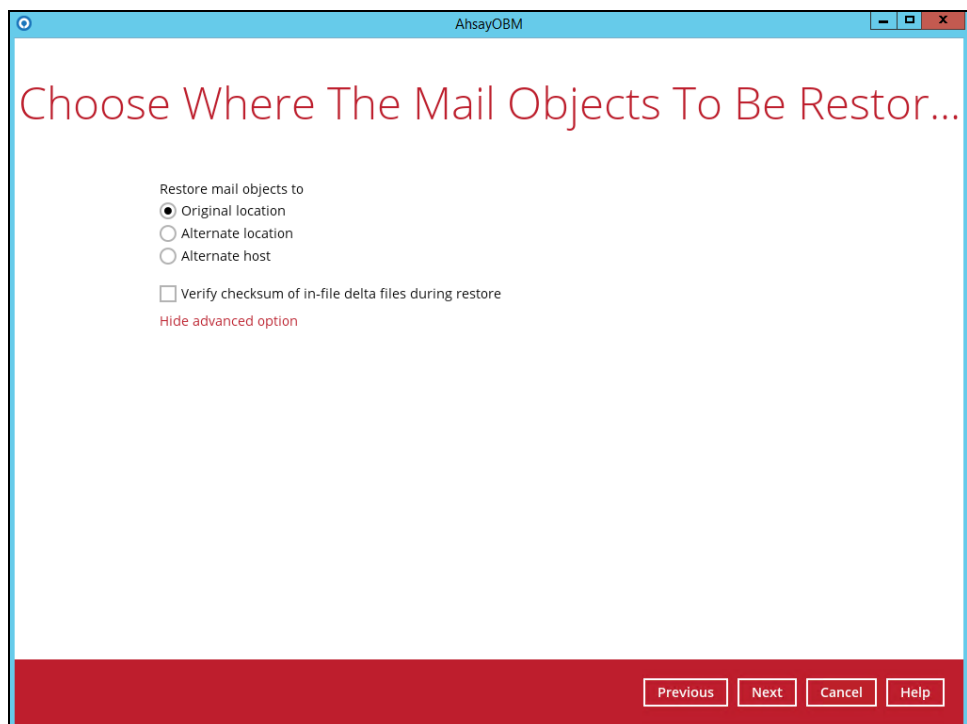
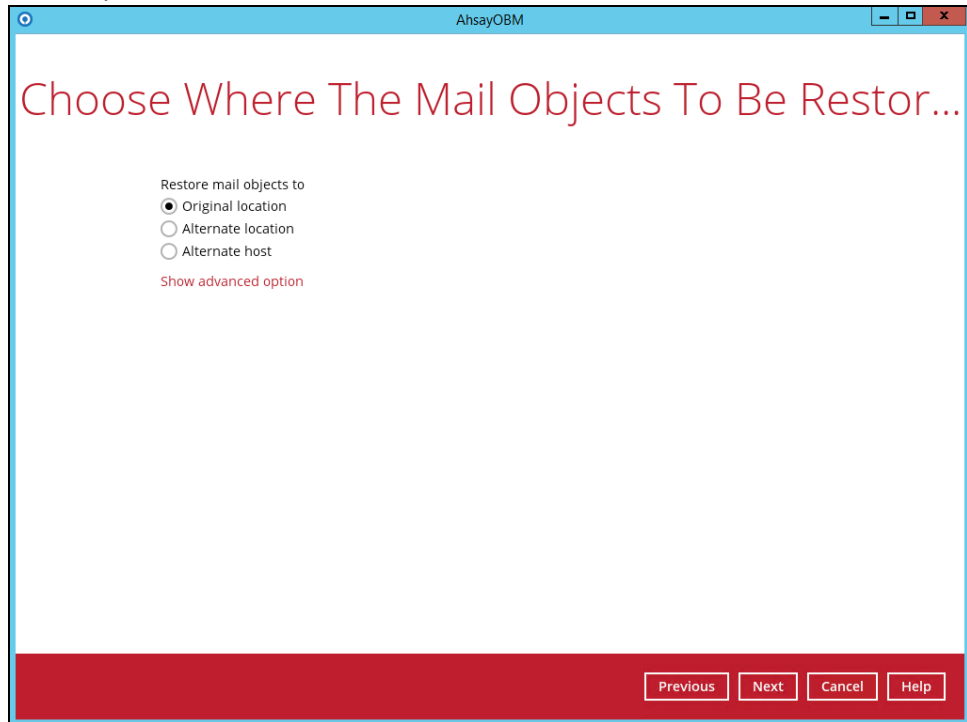

④ **Restore to Alternate Location**

You can choose to restore mailbox item(s) to another mailbox in the same Exchange server. Select the **Alternate location** option. If you would like to modify the Verify checksum of in-file delta files setting, click **Show advanced option**. Then press **Next** to proceed.

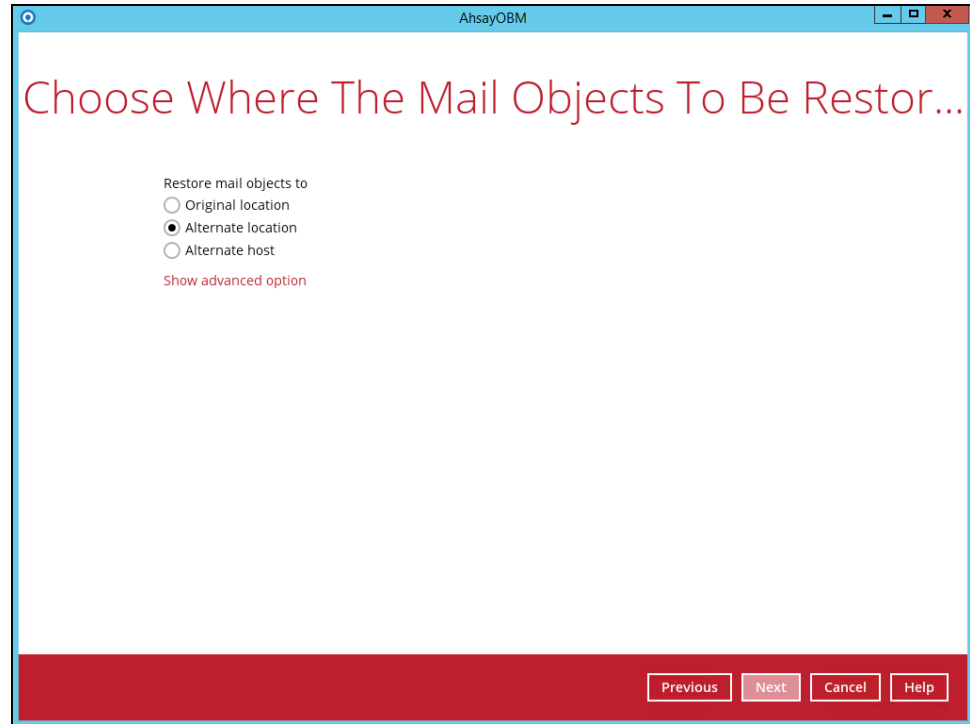

Click **Yes** then select the desired mailbox destination. Press **Next** to proceed.

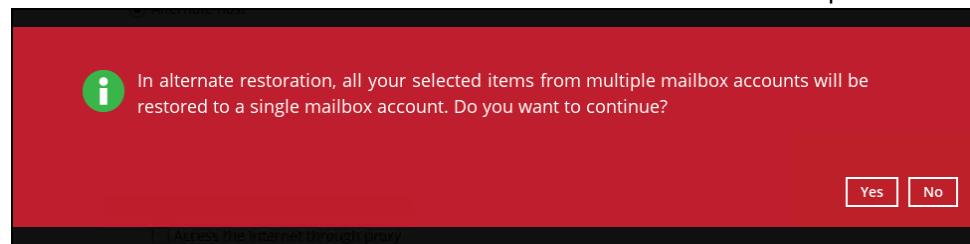

④ **Restore to Alternate Host**

You can also choose to restore mailbox item(s) to a different Exchange server of the same version. Select the **Alternate host** option. Enter the hostname, username and password of the alternate Exchange server. If you will access the internet through proxy, check the box beside it and set the configuration for the proxy server and click **Save**. If you would like to modify the Verify checksum of in-file delta files setting, click **Show advanced option**.

Proxy (HTTP)

IP address Port

Login ID

Password

Click **Yes** then select the desired mailbox destination. Press **Next** to proceed.

 In alternate restoration, all your selected items from multiple mailbox accounts will be restored to a single mailbox account. Do you want to continue?

AhsayOBM

Alternate Location

Host

User

- Administrator@xch16dag.ahsay.com ▼
- Administrator@xch16dag.ahsay.com
- backup@xch16dag.ahsay.com
- user01@xch16dag.ahsay.com
- user02@xch16dag.ahsay.com
- user03@xch16dag.ahsay.com

Please refer to the [Limitation](#) part to check for limitation of the restore process.

6. Select the temporary directory for storing temporary files, such as delta files when they are being merged, click **Restore** to start the restoration.

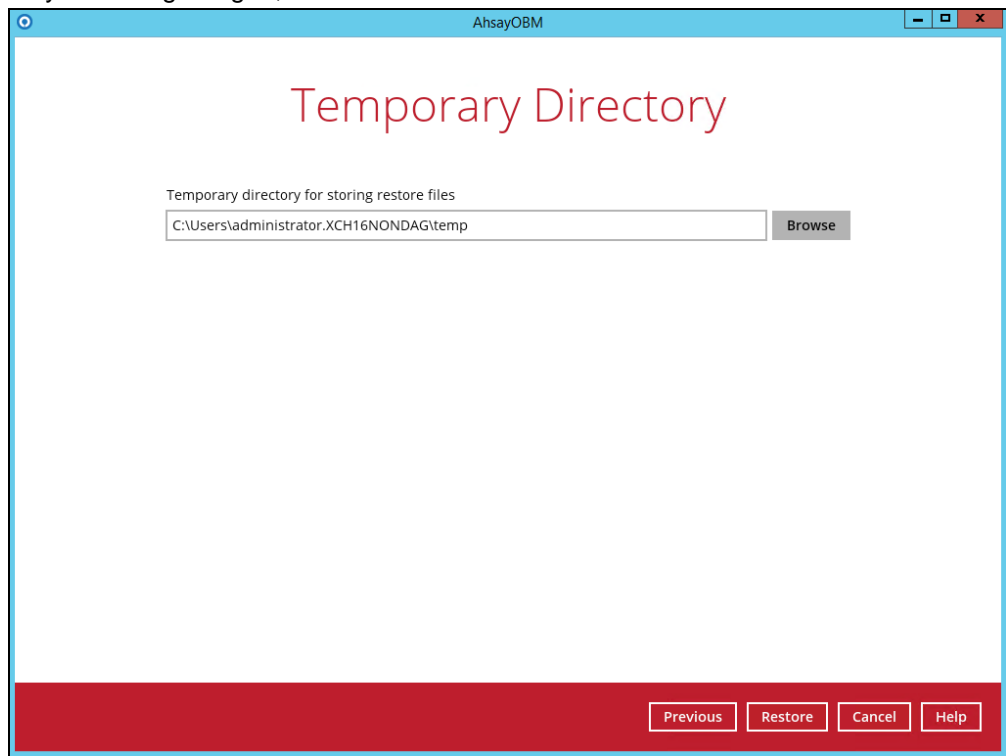

7. The following screen with the text **Restore Completed Successfully** shows when the restoration is completed.

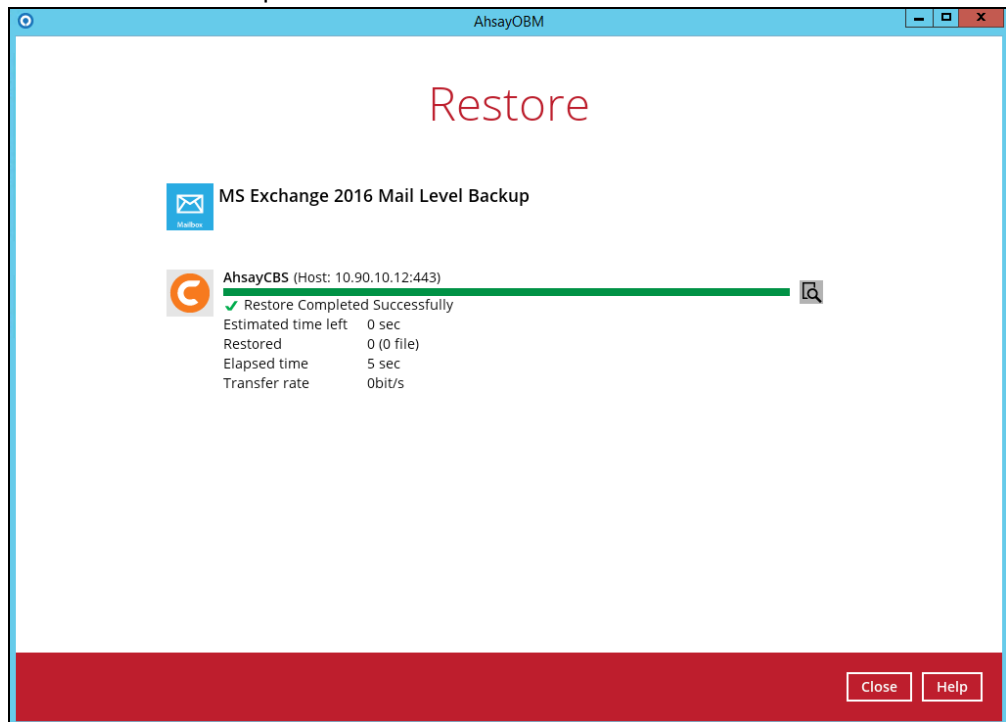

5.2 Database Availability Group (DAG) Backup Option

5.2.1 Create Mail Level Backup Set

1. Click the **Backup Sets** icon on the main interface of AhsayOBM.



2. Create a new backup set by clicking the “+” icon next to **Add new backup set**.
3. Select the Backup set type as **MS Exchange Mail Level Backup**. The system will automatically detect and select the Exchange Server version, make sure the version selected is correct.

- ⦿ Name your new backup set.
- ⦿ Select from the following version:
 - Microsoft Exchange Server 2013
 - Microsoft Exchange Server 2016
 - Microsoft Exchange Server 2019
 - Microsoft Exchange Server 2013 (DAG)
 - Microsoft Exchange Server 2016 (DAG)
 - Microsoft Exchange Server 2019 (DAG)

As AhsayOBM is installed on directly on the MS Exchange server. The correct MS Exchange version will be automatically selected.

- ⦿ Enter the hostname of all the DAG Member Server.
- ⦿ Enter the username and password of the Windows user account used for backup.
- ⦿ Check the “Access the Internet through proxy” if required.
- ⦿ Then click **Next** to proceed.

AhsayOBM

Create Backup Set

Name
MS Backup 2016 Mail Level Backup (DAG)

Backup set type
MS Exchange Mail Level Backup

Version
Microsoft Exchange Server 2007
Microsoft Exchange Server 2010
Microsoft Exchange Server 2013
Microsoft Exchange Server 2016
Microsoft Exchange Server 2019
Microsoft Exchange Server 2010 (DAG)
Microsoft Exchange Server 2013 (DAG)
Microsoft Exchange Server 2016 (DAG)

Next Cancel Help

AhsayOBM

Create Backup Set

Name
MS Backup 2016 Mail Level Backup (DAG)

Backup set type
MS Exchange Mail Level Backup

Version
Microsoft Exchange Server 2016 (DAG)

Host (DAG Member Server)
IP address of DAG Member Server X
IP address of DAG Member Server X
Add

Username
username

Password
.....

Access the Internet through proxy

Test

Next Cancel Help

- In the **Backup Source** menu, select the mailboxes or public folders for backup. Fifty (50) users will be displayed by default. If the MS Exchange Server account consists of more than fifty (50) users or above, click the **show next 50** button to display the next users. You can expand the mailbox or public folder to select which mail folder

to back up by clicking the [+] button. You can also click **Show mails** to select an individual mail to back up. Once done, click **Next** to proceed.

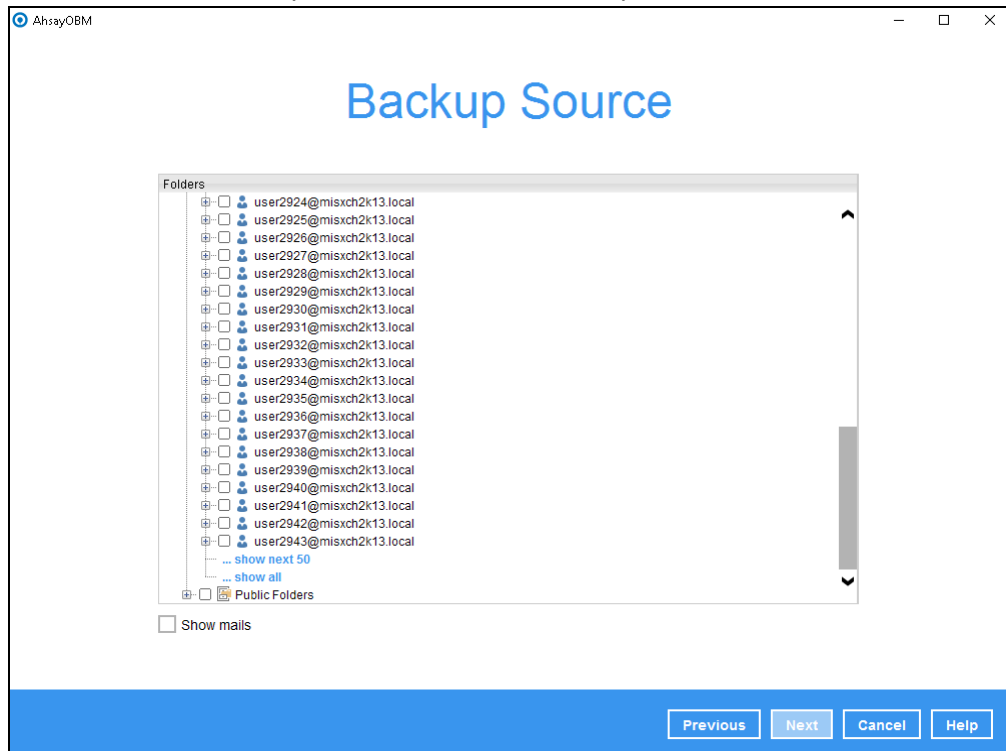

5. In the Schedule menu, you can configure a backup schedule for backup job to run automatically at your specified time interval. By default, the **Run scheduled backup for this backup set** option is disabled. Enable it, then click the “+” icon next to **Add new schedule**. Click **Next** to proceed when you are done setting.

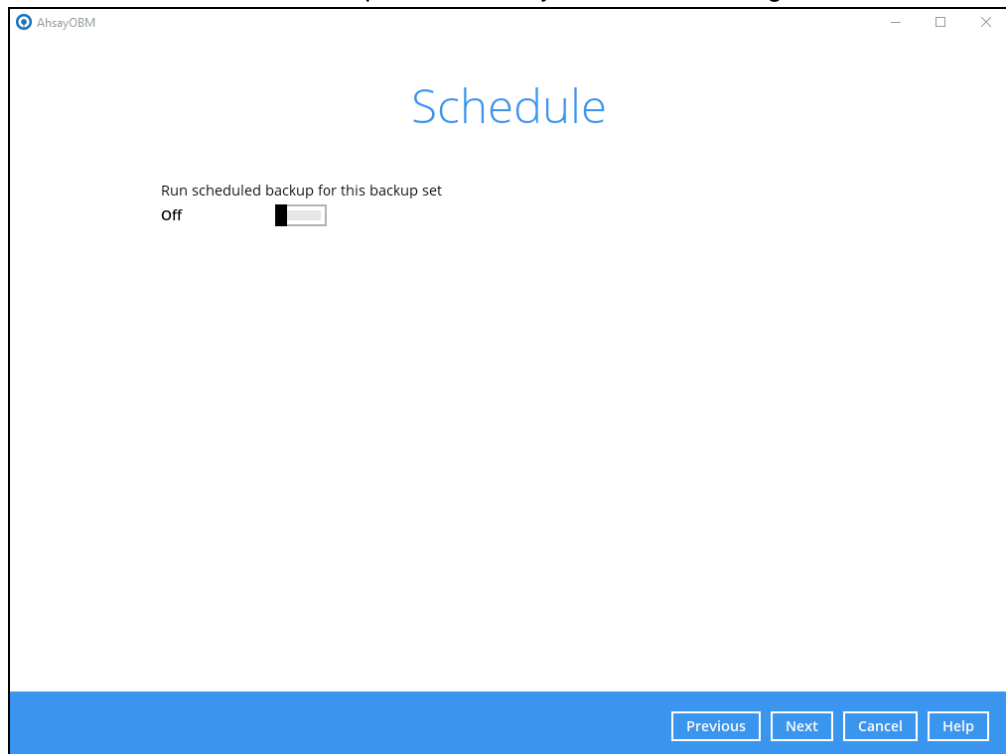

6. In the Destination menu, select a backup destination where the backup mail will be stored. Click the “+” icon next to **Add new storage destination / destination pool**.

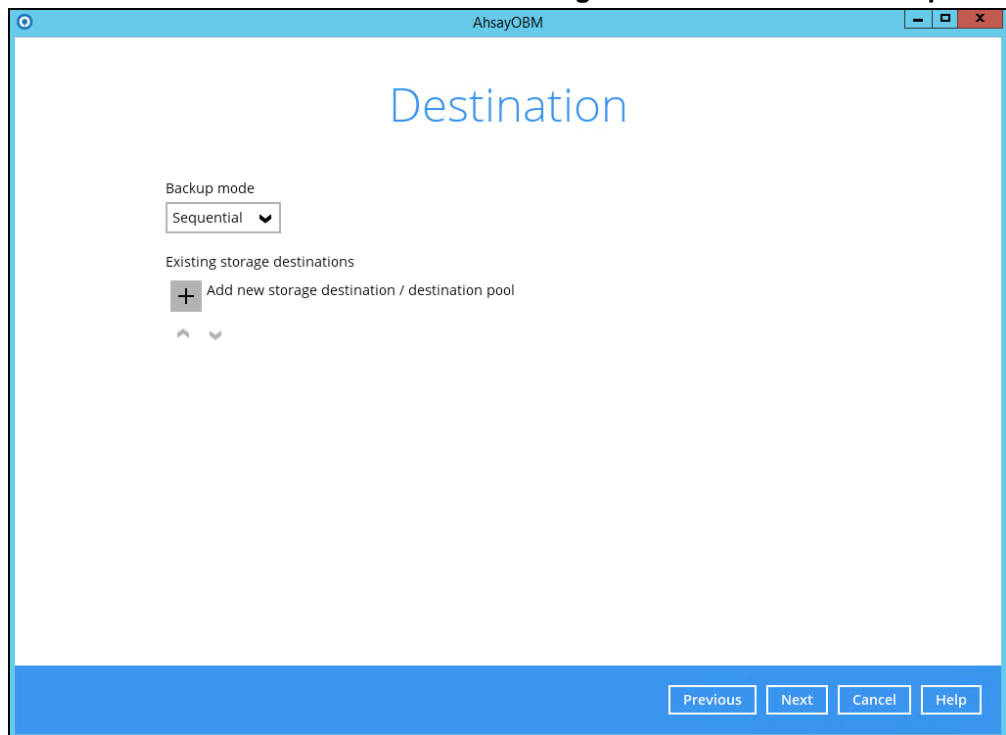

7. Select the destination storage, then click **OK** to proceed.

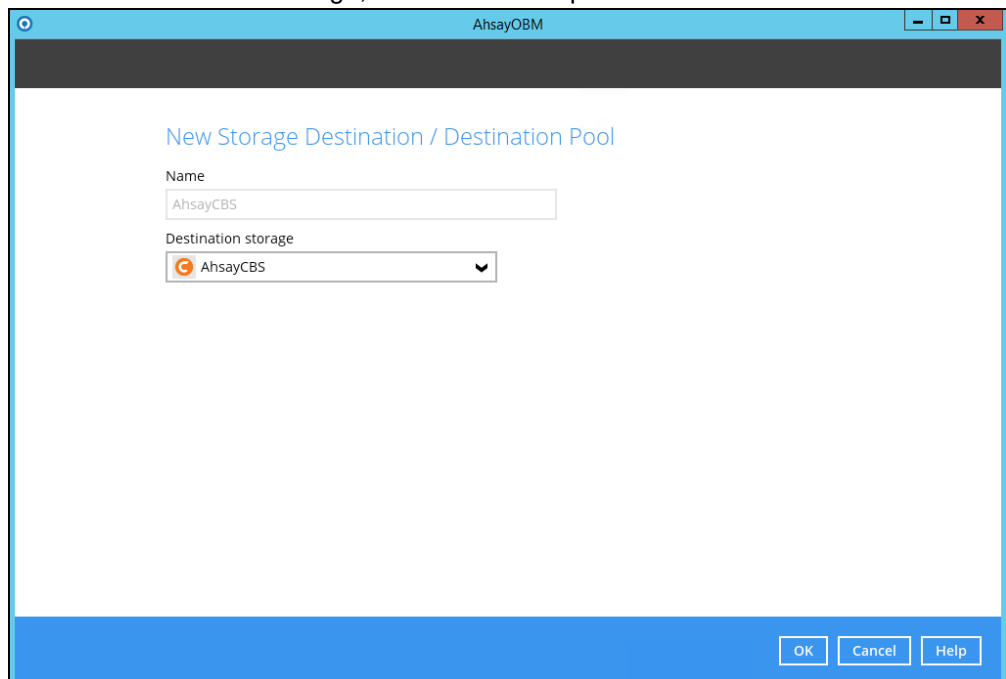

8. Click **Next** on the Destination menu page to proceed.

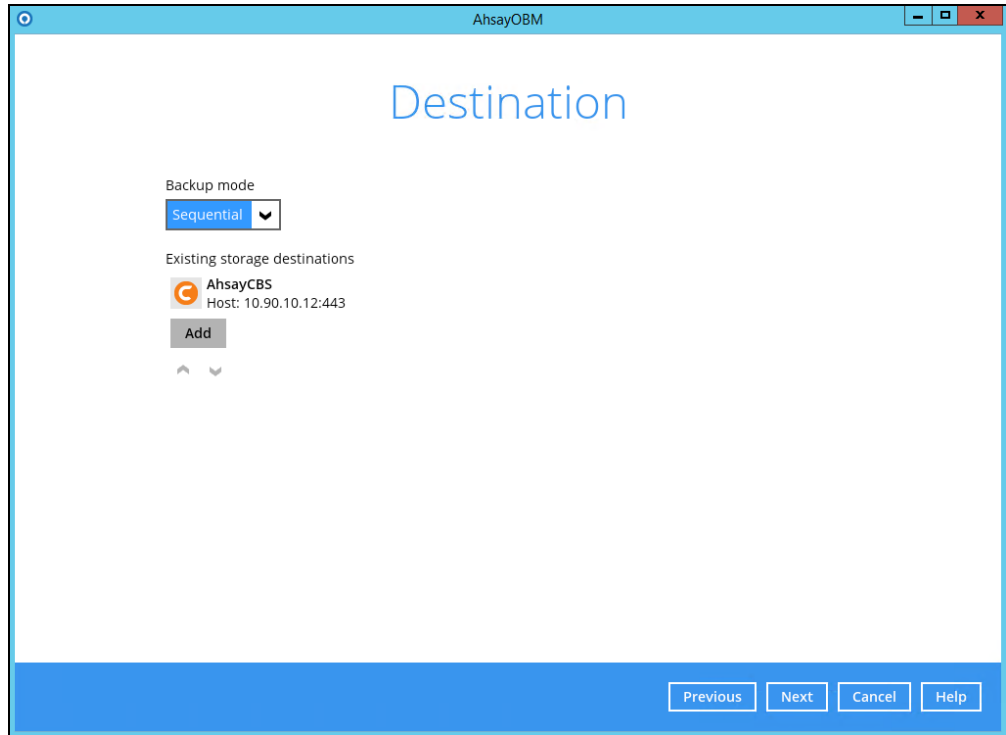

9. In the Encryption window, the default **Encrypt Backup Data** option is enabled with an encryption key preset by the system which provides the most secure protection.

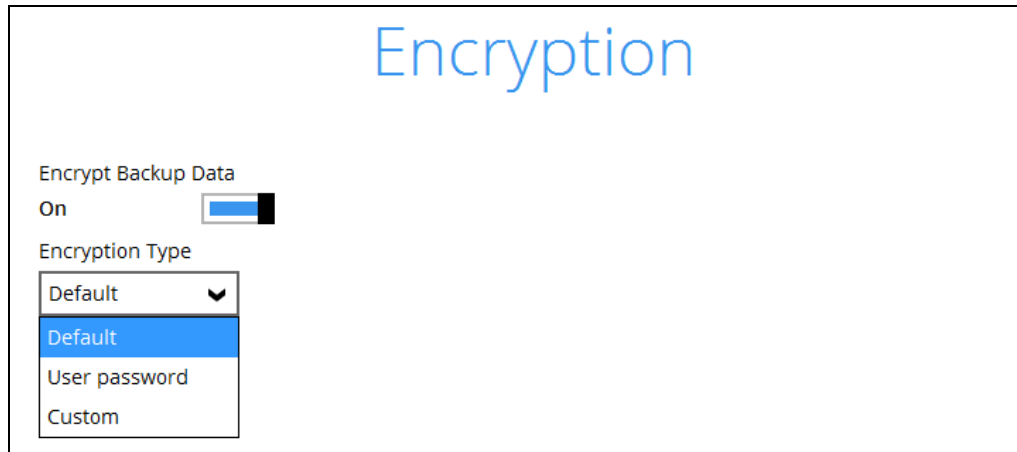

10. You can choose from one of the following three Encryption Type options:
- **Default** – an encryption key with 44 alpha numeric characters will be randomly generated by the system
 - **User password** – the encryption key will be the same as the login password of your AhsayOBM at the time when this backup set is created. Please be reminded that if you change the AhsayOBM login password later, the encryption keys of the backup sets previously created with this encryption type will remain unchanged.

- **Custom** – you can customize your encryption key, where you can set your own algorithm, encryption key, method and key length.

The screenshot shows the 'Encryption' settings page. At the top, the word 'Encryption' is displayed in a large blue font. Below it, there are several configuration options: 'Encrypt Backup Data' is set to 'On' with a blue toggle switch; 'Encryption Type' is set to 'Custom' in a dropdown menu; 'Algorithm' is set to 'AES' in a dropdown menu; 'Encryption key' and 'Re-enter encryption key' are both represented by text boxes containing seven asterisks; 'Method' has two radio buttons, with 'CBC' selected; and 'Key length' has two radio buttons, with '256-bit' selected.

NOTE

For best practice on managing your encryption key, refer to the following article: [Best Practices for Managing Encryption Key on AhsayOBM or AhsayACB.](#)

Click **Next** when you are done setting.

11. If you have enabled the Encryption Key feature in the previous step, the following pop-up window shows, no matter which encryption type you have selected.

The screenshot shows a confirmation pop-up window titled 'Encryption'. The background is dark grey. The text reads: 'You are advised to write this encryption key down on paper and keep it in a safe place. You will need it when you need to restore your files later. Please confirm that you have done so.' Below this text is a text box containing seven black dots, representing the encryption key. Underneath the text box is the label 'Unmask encryption key'. At the bottom right, there are two buttons: 'Copy to clipboard' and 'Confirm'.

The pop-up window has the following three options to choose from:

- **Unmask encryption key** – The encryption key is masked by default. Click this option to show the encryption key.

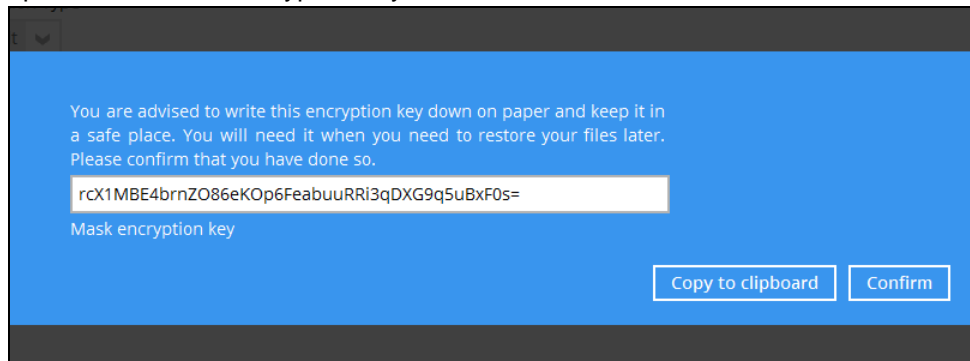

- **Copy to clipboard** – Click to copy the encryption key, then you can paste it in another location of your choice.
- **Confirm** – Click to exit this pop-up window and proceed to the next step

12. Enter the Windows login credentials for user authentication. Click **Next** to proceed. The User name should be entered in the following format "user@hostname", i.e. administrator@ahsay.com

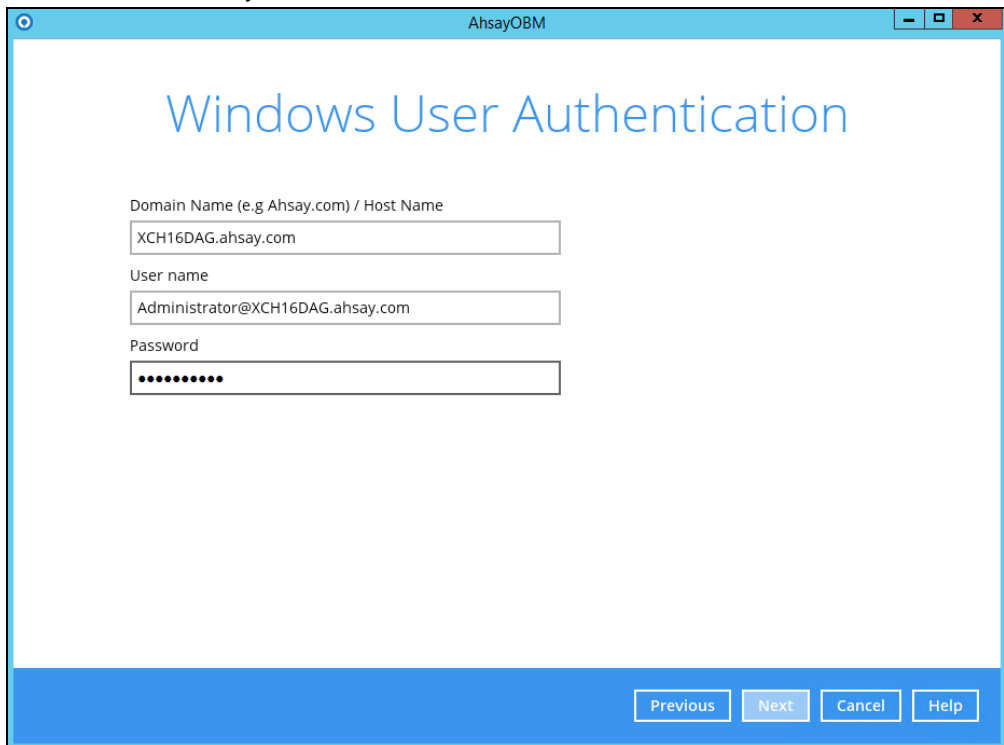

NOTE

The Windows User Authentication interface will show only if scheduled backup is enabled and set successfully.

13. The following screen shows when the new backup set is created successfully.

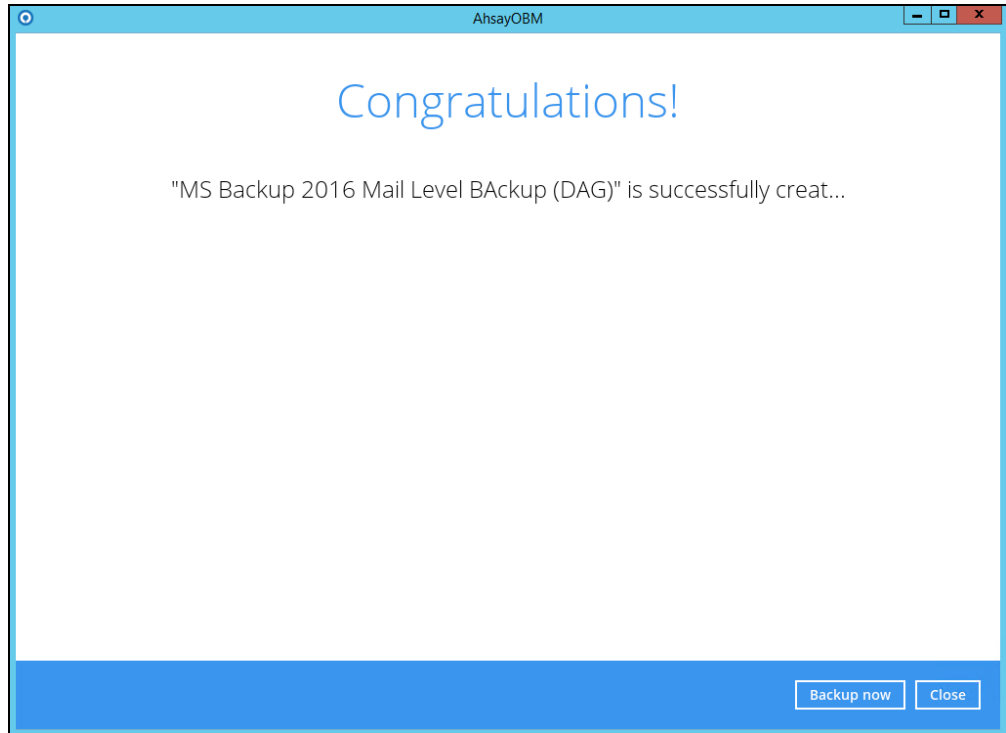

14. Click Backup now to start a backup immediately, or you can run a backup job later by following the instructions in [Run Mail Level Backup Job](#)
15. Based on [Best Practices and Recommendations](#), it is highly recommended to set the **temporary directory** to another location other than Drive C: (e.g. Drive E:). To do this, go to **Backup Sets > Others > Temporary Directory** and click the **Change** button to browse for another location.

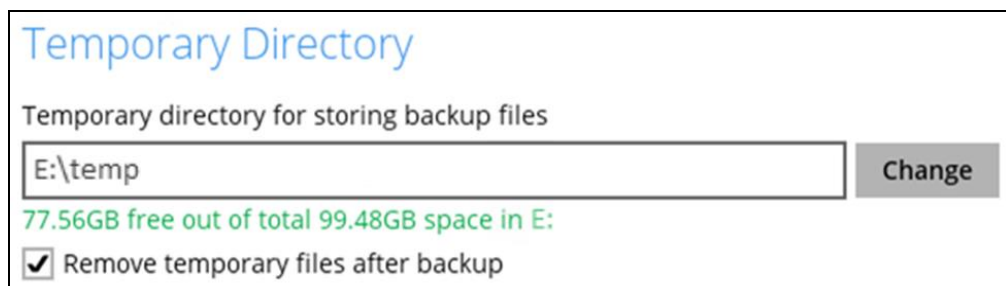

16. Optional: Select your preferred **Compression** type. By default, the compression type is Fast with optimization for local.

Go to **Others > Compressions**, then select from the following:

- No Compression
- Normal
- Fast (Compressed size larger than normal)
- Fast with optimization for local

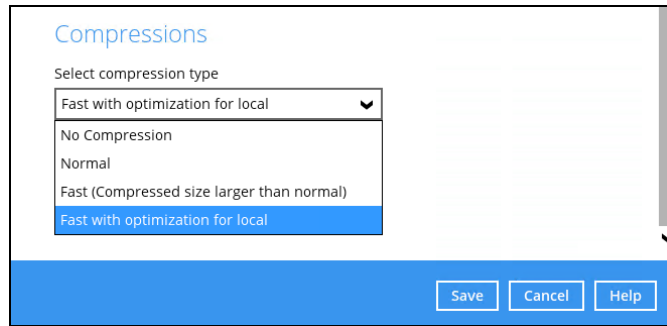

5.2.2 Run Mail Level Backup Job

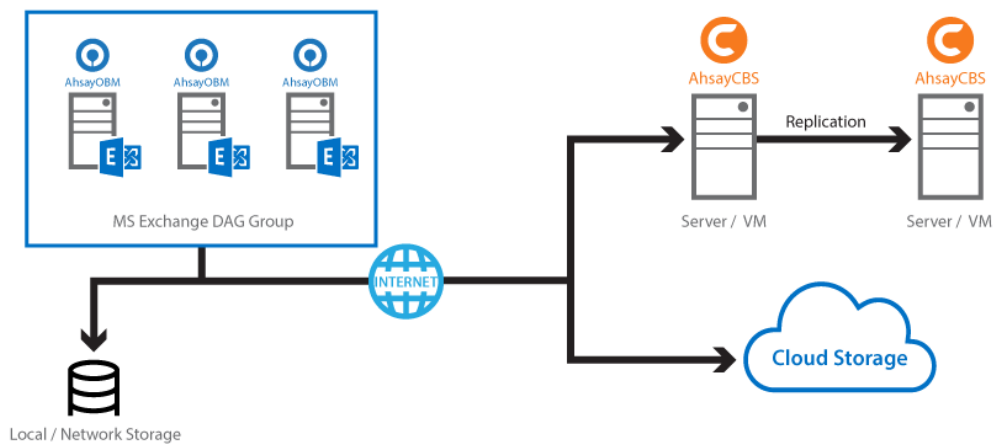

As mentioned in the [Requirement](#) section of this guide, if you choose to back up an Exchange DAG setup by installing AhsayOBM on each DAG members, only a scheduled backup that is performed on all DAG members at the scheduled time, will be considered a complete backup. AhsayOBM on all DAG members will start a backup, based on the scheduled time of the backup set at the same time.

A manual backup performed only on individual DAG member will not be considered complete.

Please refer to the [Scheduled Backup for Exchange Server in Data Availability Group \(DAG\) Option](#) for details.

5.2.3 Restore Mail Level Backup

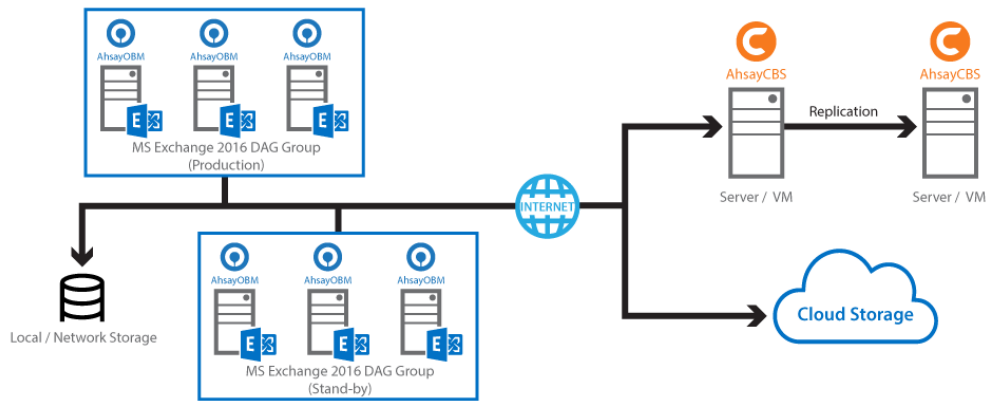

Below are the steps of the restore process.

1. In the AhsayOBM main interface, click the **Restore** icon.

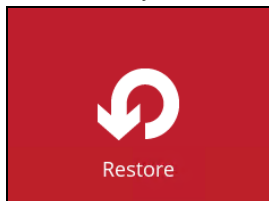

2. Select the backup set that you would like to restore mail from.

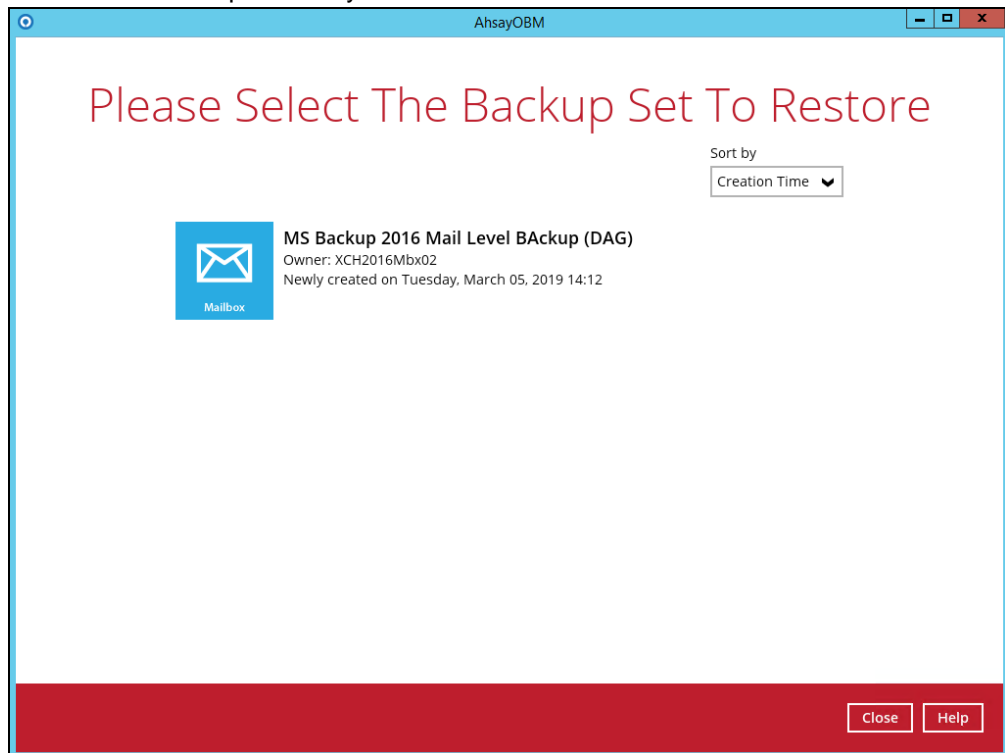

3. Select the backup destination that contains the mail(s) that you would like to restore.



4. Click to expand the menu tree to select which mailbox to restore. You can also select mail item(s) from a specific backup job or all mail items that you have backed up to restore. Click **Next** to proceed.

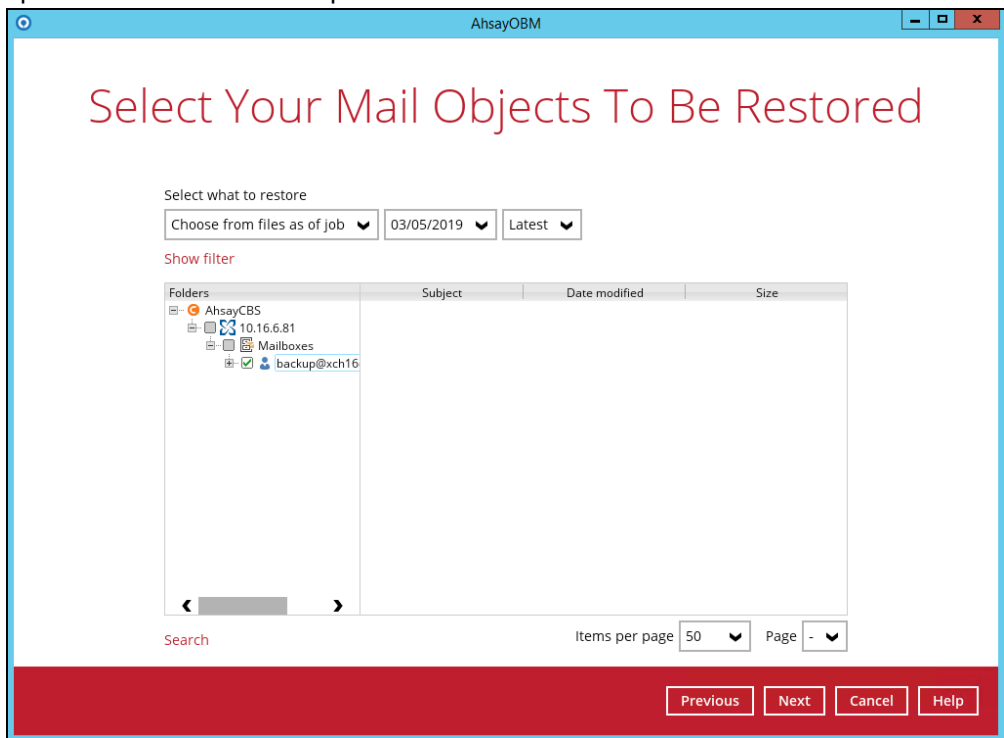

5. Select to restore the mail to their Original location, Alternate location or to an Alternate host.

⦿ **Restore to Original Location**

Select the **Original location** option. If you would like to modify the Verify checksum of in-file delta files setting, click **Show advanced option**. Then press **Next** to proceed.

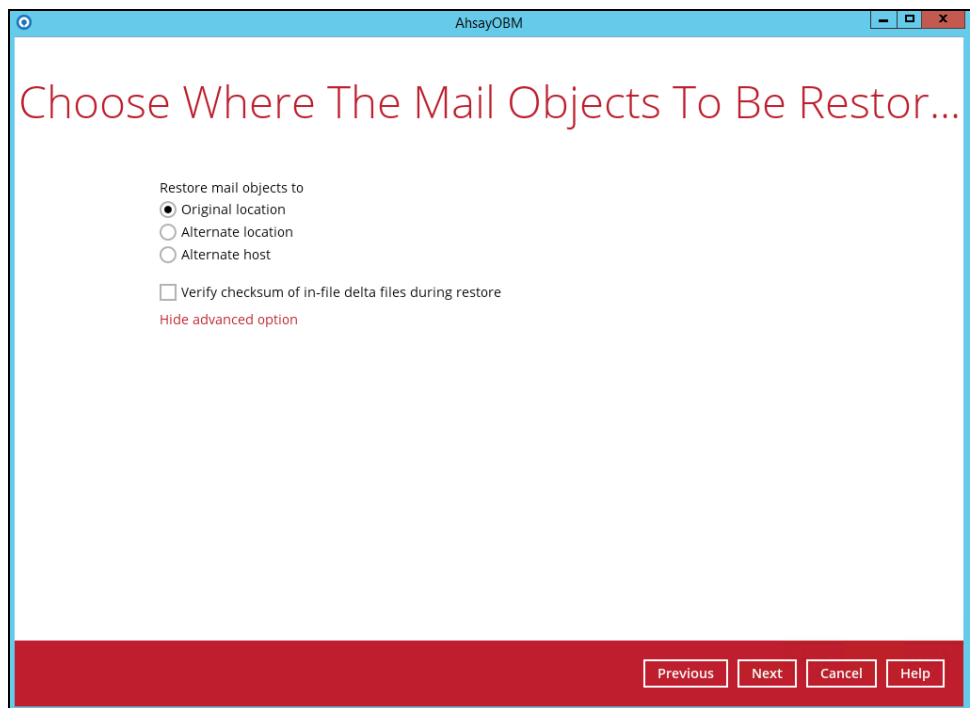
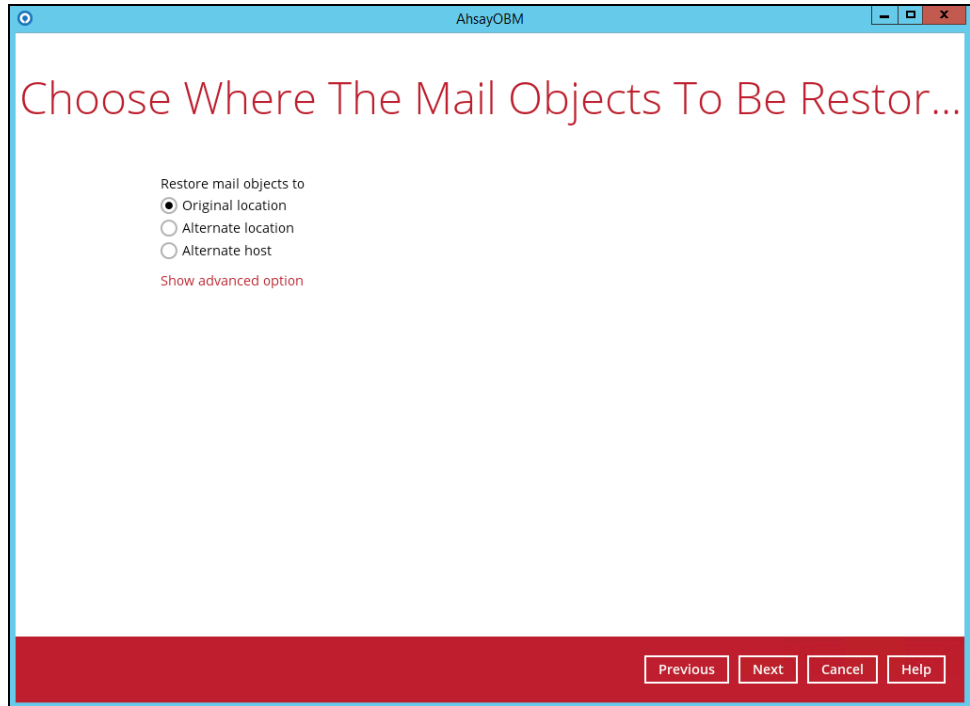

Restore to Alternate Mailbox

You can choose to restore mailbox item(s) to another mailbox in the same Exchange server. Select the **Alternate location** option. If you would like to modify the Verify checksum of in-file delta files setting, click **Show advanced option** then press **Next**. Select the desired mailbox destination, then press **Next** to proceed.

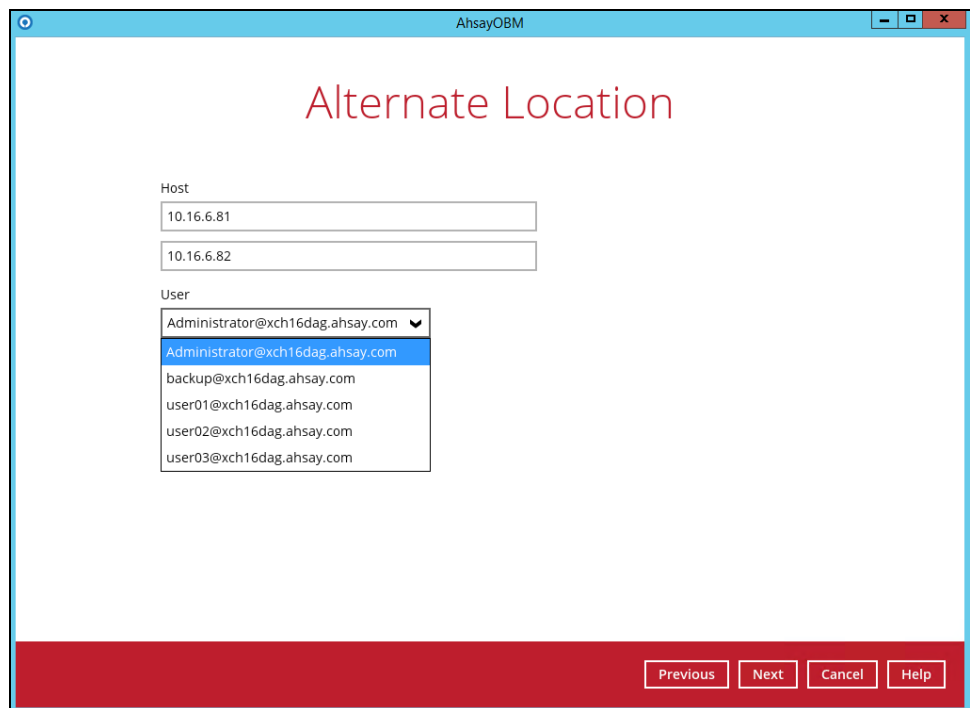
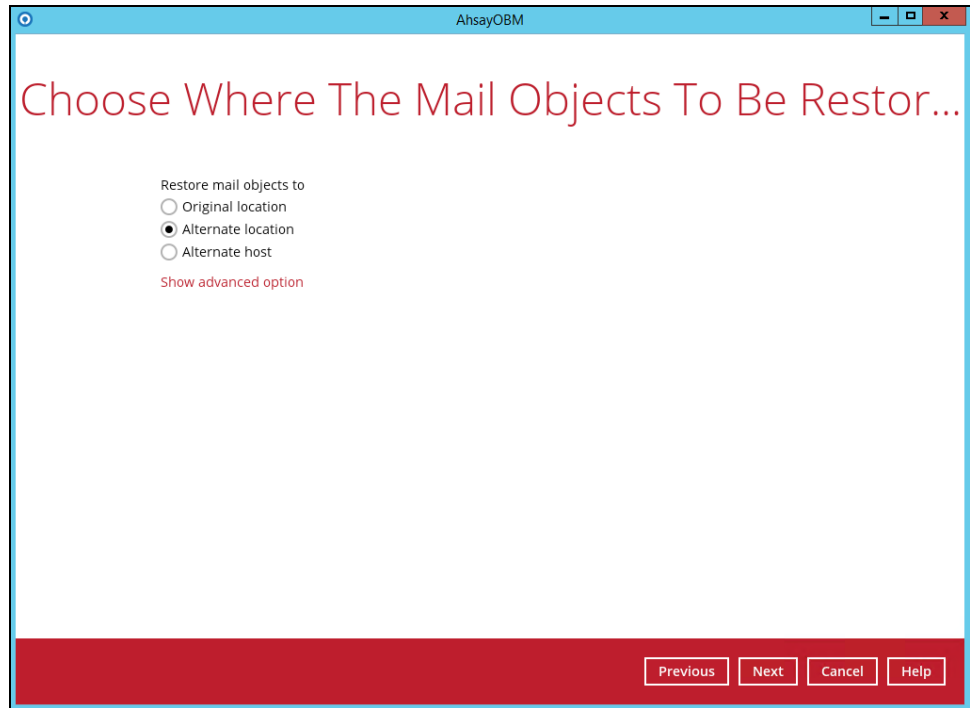

Restore to Alternate Host

You can also choose to restore mailbox item(s) to another mailbox in another Exchange server of the same version. Select the **Alternate host** option. Enter the host, username and password of the alternate Exchange server. If you will access the internet through proxy, check the box beside it and set the configuration for the proxy server and click **Save**. If you would like to modify the Verify checksum of in-file delta files setting, click **Show advanced option**.

Choose Where The Mail Objects To Be Restor...

Restore mail objects to

Original location

Alternate location

Alternate host

Host

10.16.6.81

Username

backup

Password

••••••

Access the Internet through proxy

Test

Show advanced option

Previous Next Cancel Help

Proxy (HTTP)

IP address Port

Login ID

Password

Test connection

Save Cancel

Select the desired mailbox destination then press **Next** proceed.

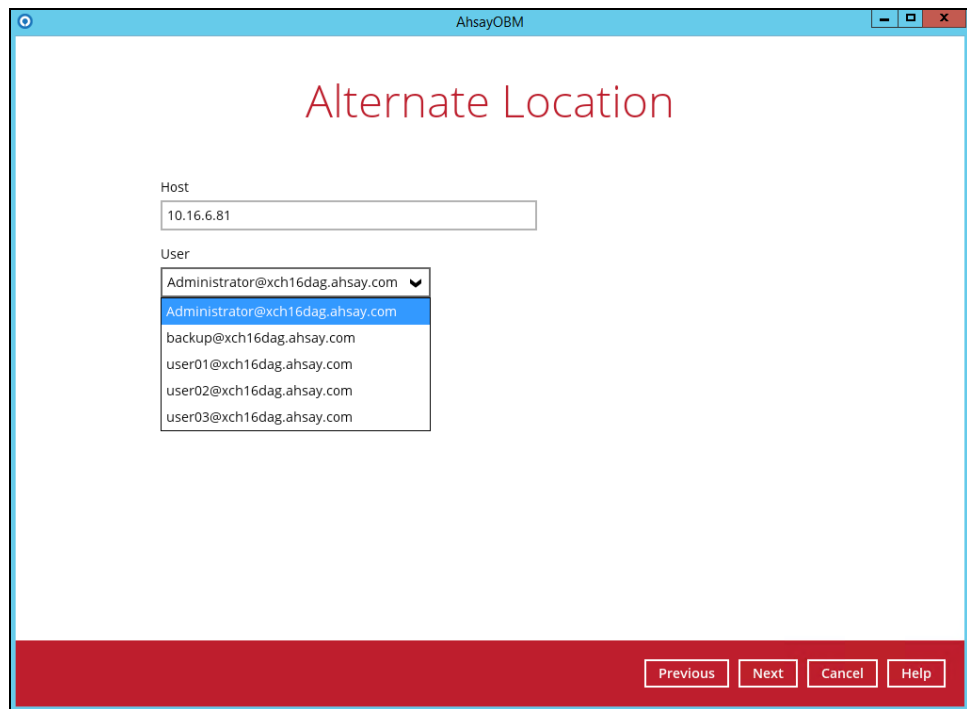

Please refer to the [Limitation](#) part to check for the limitation of the restore process.

6. Select the temporary directory for storing temporary files, such as delta files when they are being merged, click **Restore** to start the restoration.

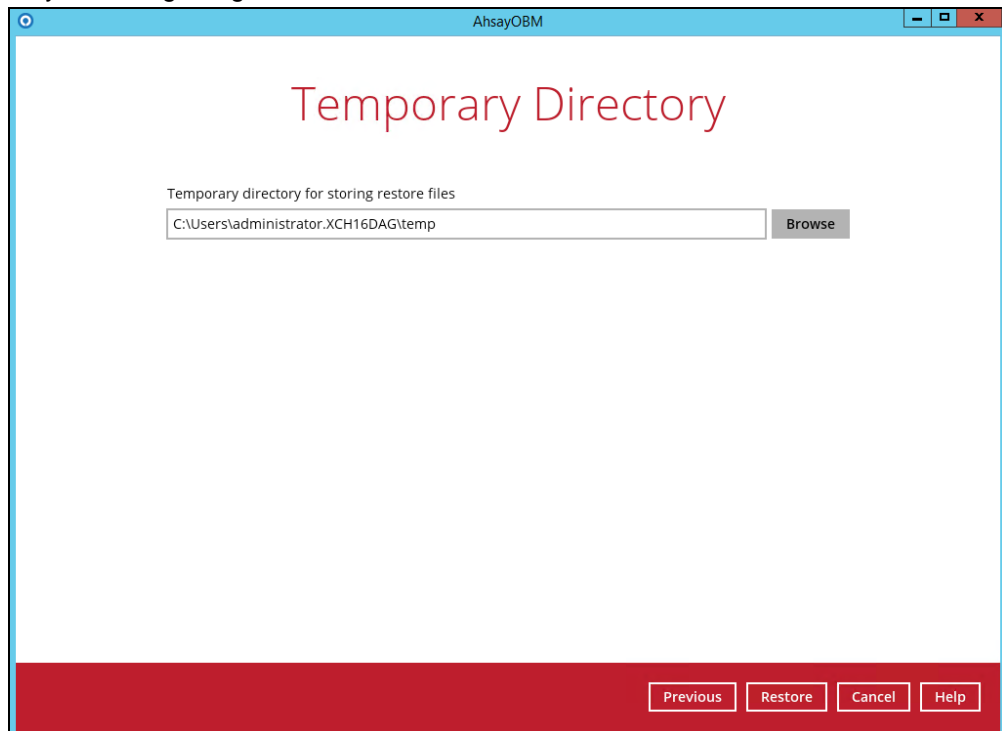

7. The following screen with the text **Restore Completed Successfully** shows when the restoration is completed.

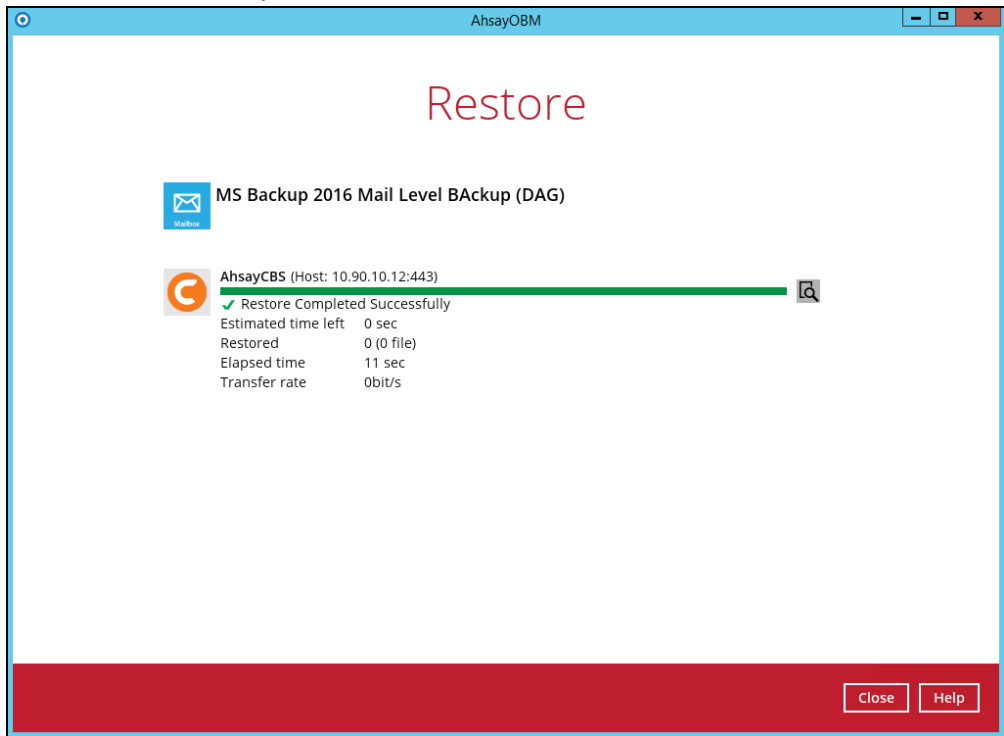

6 On Remote Backup Machine

6.1 Standalone Backup Option

6.1.1 Create Mail Level Backup Set

1. Click the **Backup Sets** icon on the main interface of AhsayOBM.



2. Create a new backup set by clicking the “+” icon next to **Add new backup set**.
3. Select the Backup set type as **MS Exchange Mail Level Backup**.

- ⊙ Name your new backup set.
- ⊙ Select from the following version:
 - Microsoft Exchange Server 2013
 - Microsoft Exchange Server 2016
 - Microsoft Exchange Server 2019
 - Microsoft Exchange Server 2013 (DAG)
 - Microsoft Exchange Server 2016 (DAG)
 - Microsoft Exchange Server 2019 (DAG)

As AhsayOBM is not installed directly on the MS Exchange 2016 / 2019 server, it cannot automatically detect the MS Exchange version. Therefore, the MS Exchange version must be selected manually.

- ⊙ Enter the hostname of Exchange server.
- ⊙ Enter the username and password of the Windows user account used for backup.
- ⊙ Check the “Access the Internet through proxy” if required.
- ⊙ Click the **Test** button to verify the login details.
- ⊙ Then click **Next** to proceed.

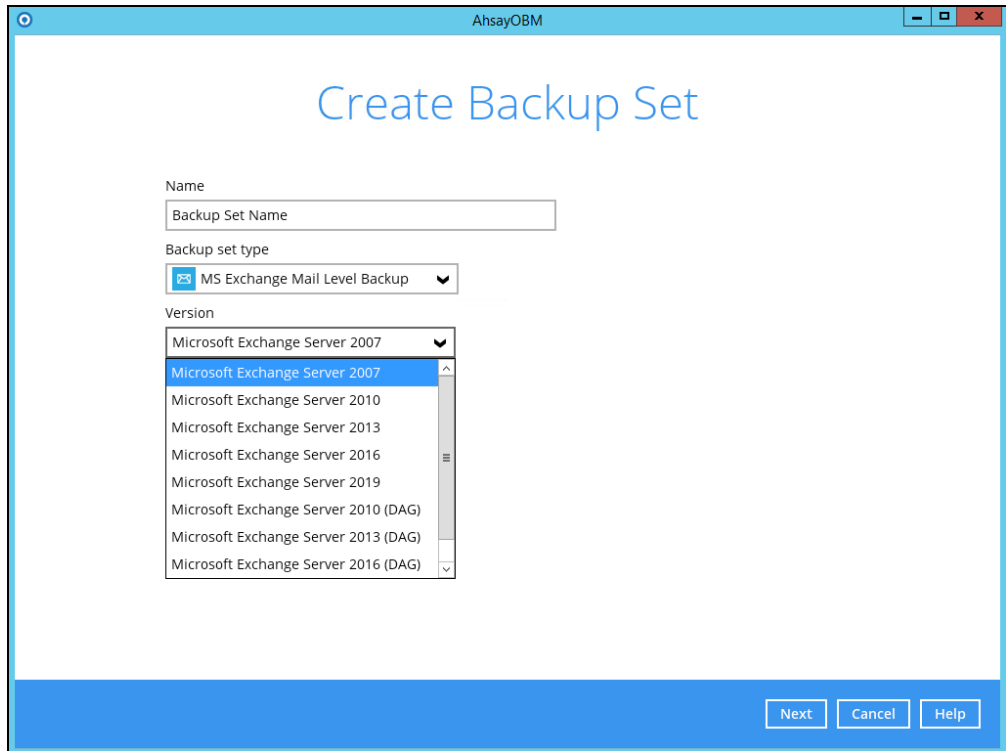

4. In the **Backup Source** menu, select the mailboxes or public folders for backup. Fifty (50) users will be displayed by default. If the MS Exchange Server account consists of more than fifty (50) users or above, click the **show next 50** button to display the next users. You can expand the mailbox or public folder to select which mail folder to back up by clicking the **[+]** button. You can also click **Show mails** to select an individual mail to back up. Once done, click **Next** to proceed.

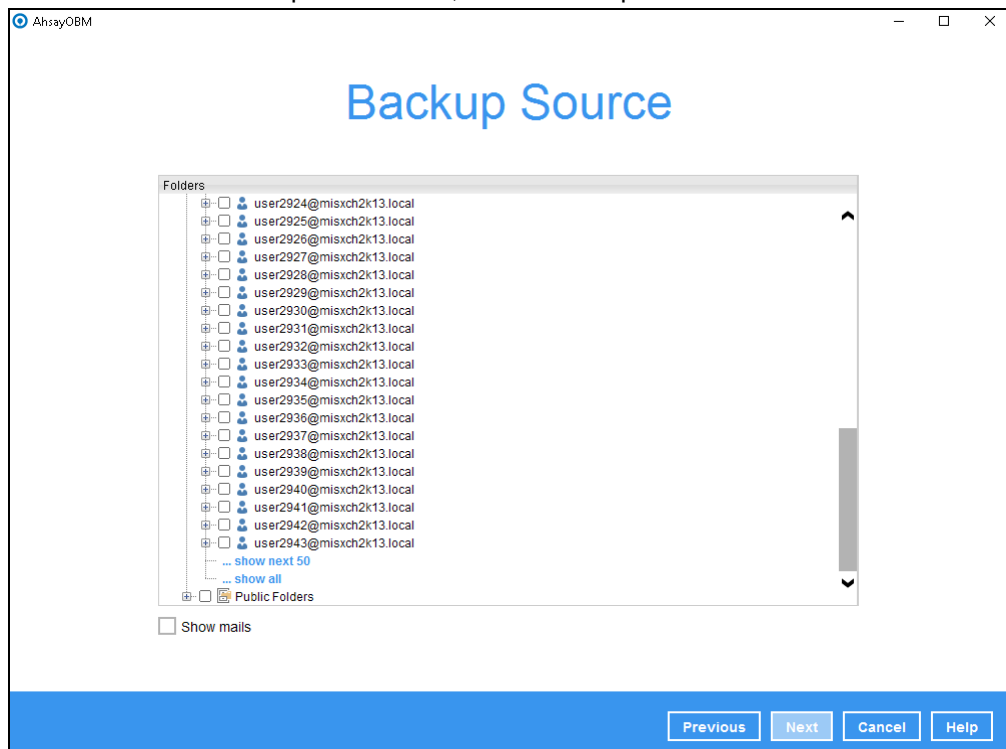

5. In the Schedule menu, you can configure a backup schedule for backup job to run automatically at your specified time interval. By default, the **Run scheduled backup for this backup set** option is disabled. Enable it, then click the “+” icon next to **Add new schedule**. Click **Next** to proceed when you are done setting.

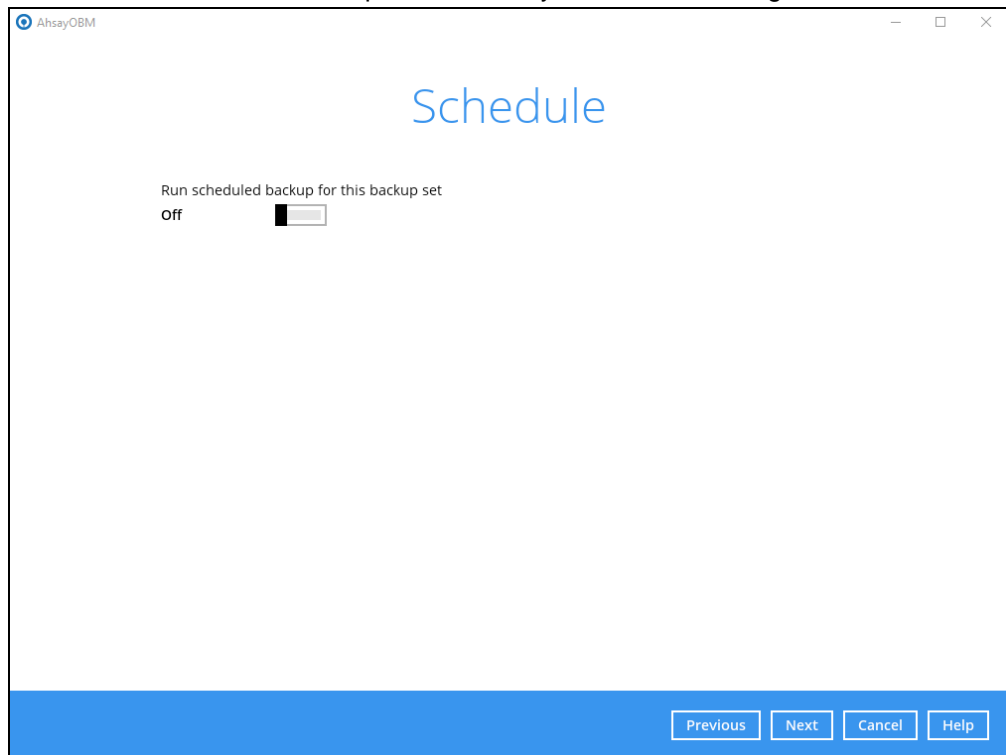

6. In the Destination menu, select a backup destination where the backup mail will be stored. Click the “+” icon next to **Add new storage destination / destination pool**.

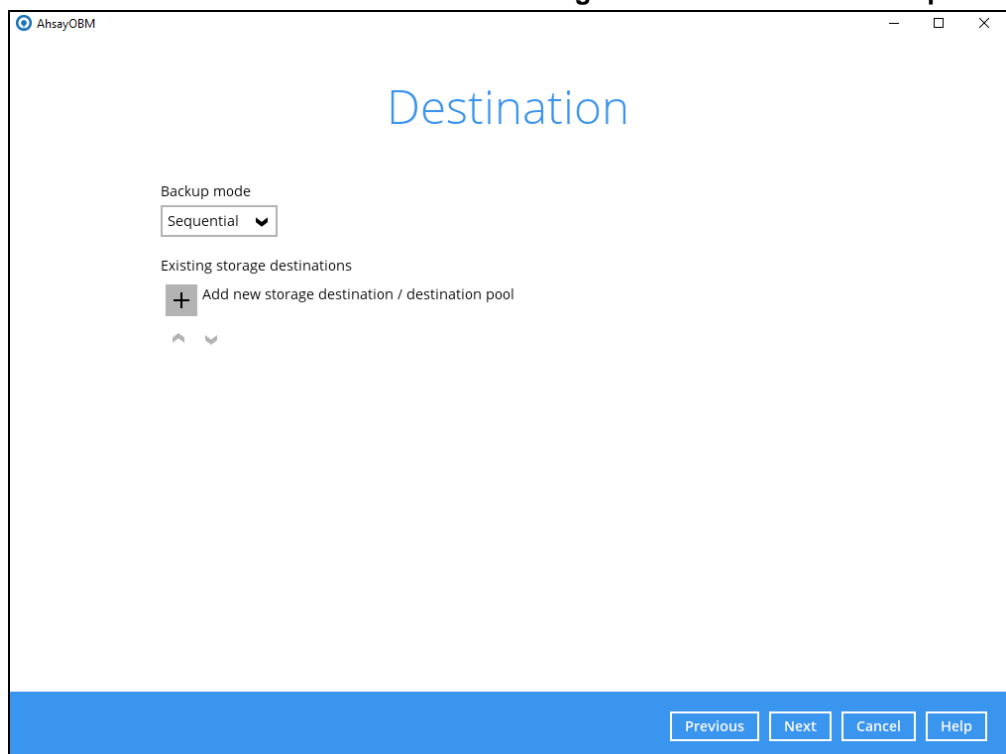

7. Select the destination storage, then click **OK** to proceed.

AhsayOBM

New Storage Destination / Destination Pool

Name
AhsayCBS

Destination storage
AhsayCBS

OK Cancel Help

8. Click **Next** on the Destination menu page to proceed.

AhsayOBM

Destination

Backup mode
Sequential

Existing storage destinations
AhsayCBS
Host: 10.90.10.12:443
Add

Previous Next Cancel Help

9. In the Encryption window, the default **Encrypt Backup Data** option is enabled with an encryption key preset by the system which provides the most secure protection.

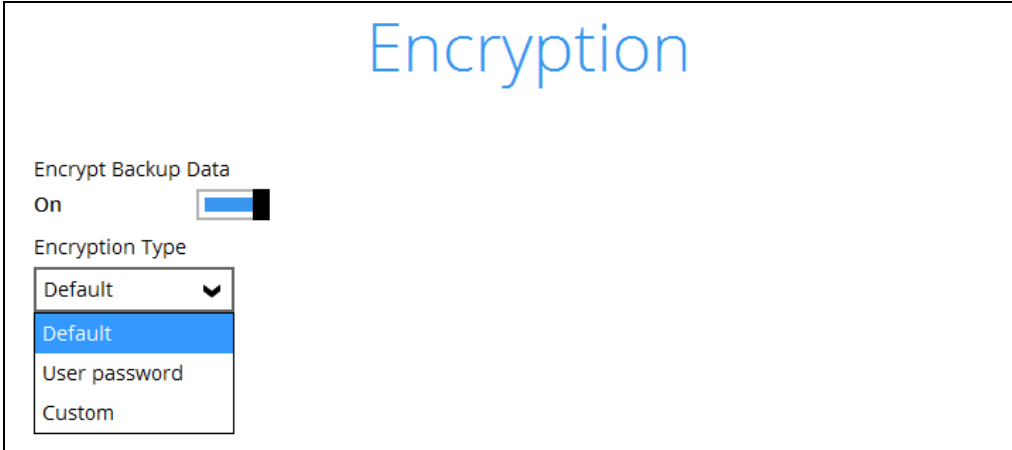

The screenshot shows the 'Encryption' window. At the top, the word 'Encryption' is displayed in a large blue font. Below it, the 'Encrypt Backup Data' option is set to 'On', indicated by a blue slider. Underneath, the 'Encryption Type' is set to 'Default' in a dropdown menu. The dropdown menu is open, showing three options: 'Default' (highlighted in blue), 'User password', and 'Custom'.

10. You can choose from one of the following three Encryption Type options:
- **Default** – an encryption key with 44 alpha numeric characters will be randomly generated by the system
 - **User password** – the encryption key will be the same as the login password of your AhsayOBM at the time when this backup set is created. Please be reminded that if you change the AhsayOBM login password later, the encryption keys of the backup sets previously created with this encryption type will remain unchanged.
 - **Custom** – you can customize your encryption key, where you can set your own algorithm, encryption key, method and key length.

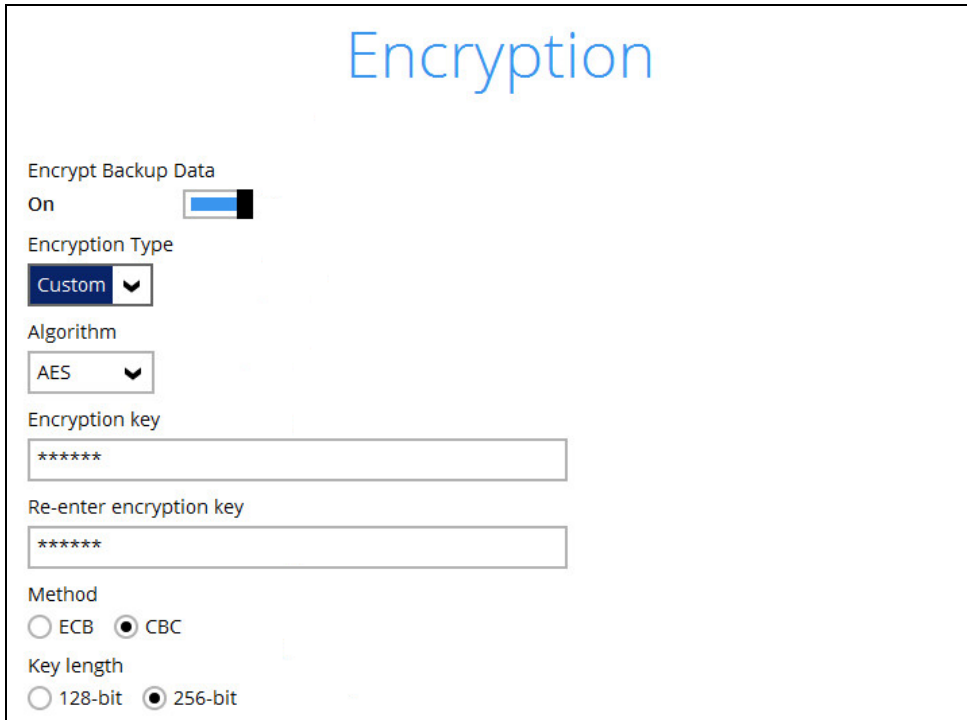

The screenshot shows the 'Encryption' window with 'Encrypt Backup Data' set to 'On'. The 'Encryption Type' is set to 'Custom'. Below this, the 'Algorithm' is set to 'AES'. There are two text input fields for the 'Encryption key', both containing six asterisks. The 'Method' is set to 'CBC' (selected with a radio button), and the 'Key length' is set to '256-bit' (selected with a radio button).

NOTE

For best practice on managing your encryption key, refer to the following article: [Best Practices for Managing Encryption Key on AhsayOBM or AhsayACB.](#)

Click **Next** when you are done setting.

11. If you have enabled the Encryption Key feature in the previous step, the following pop-up window shows, no matter which encryption type you have selected.

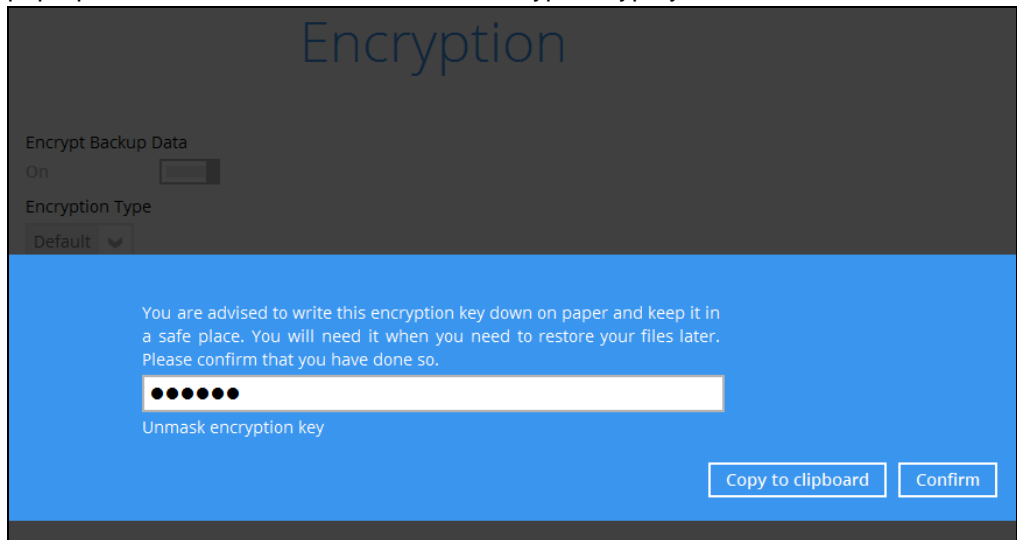

The pop-up window has the following three options to choose from:

- **Unmask encryption key** – The encryption key is masked by default. Click this option to show the encryption key.

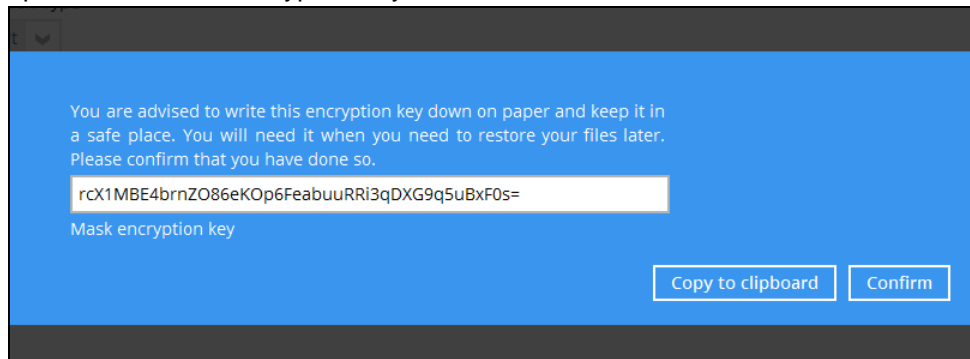

- **Copy to clipboard** – Click to copy the encryption key, then you can paste it in another location of your choice.
- **Confirm** – Click to exit this pop-up window and proceed to the next step

12. Enter the Windows login credentials for user authentication. Click **Next** to proceed. The User name should be entered in the following format "user@hostname", i.e. administrator@ahsay.com

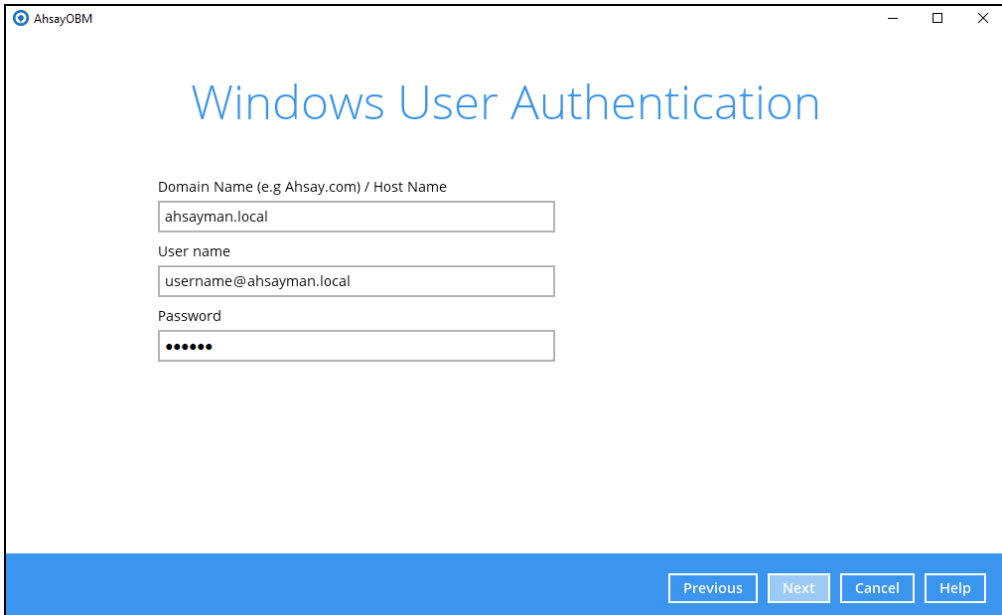

NOTE

The Windows User Authentication interface will show only if scheduled backup is enabled and set successfully.

13. The following screen shows when the new backup set is created successfully.

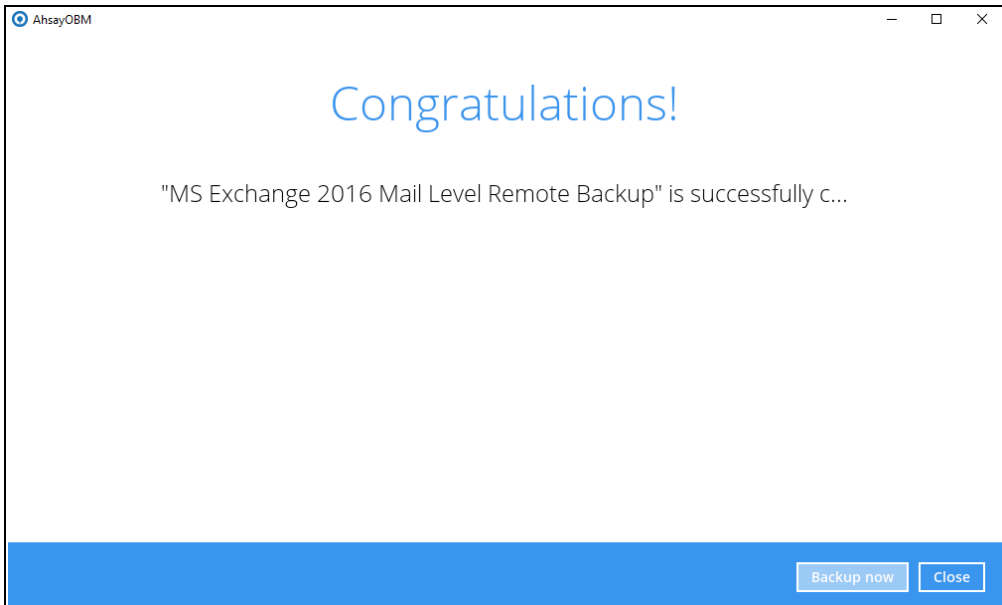

14. Click **Backup now** to start a backup immediately, or you can run a backup job later by following the instructions in [Run Mail Level Backup Job](#)
15. Based on [Best Practices and Recommendations](#), it is highly recommended to set the **temporary directory** to another location other than Drive C: (e.g. Drive E:). To do this, go to **Backup Sets > Others > Temporary Directory** and click the **Change** button to browse for another location.

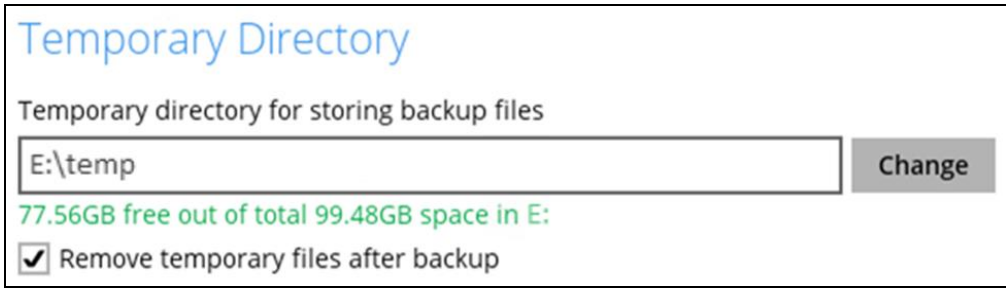

16. Optional: Select your preferred **Compression** type. By default, the compression type is Fast with optimization for local.

Go to **Others > Compressions**, then select from the following:

- No Compression
- Normal
- Fast (Compressed size larger than normal)
- Fast with optimization for local

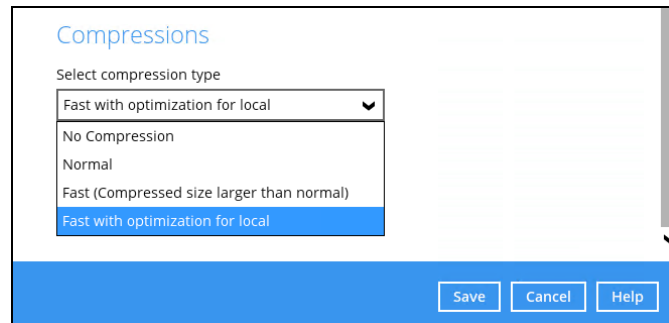

6.1.2 Run Mail Level Backup Job

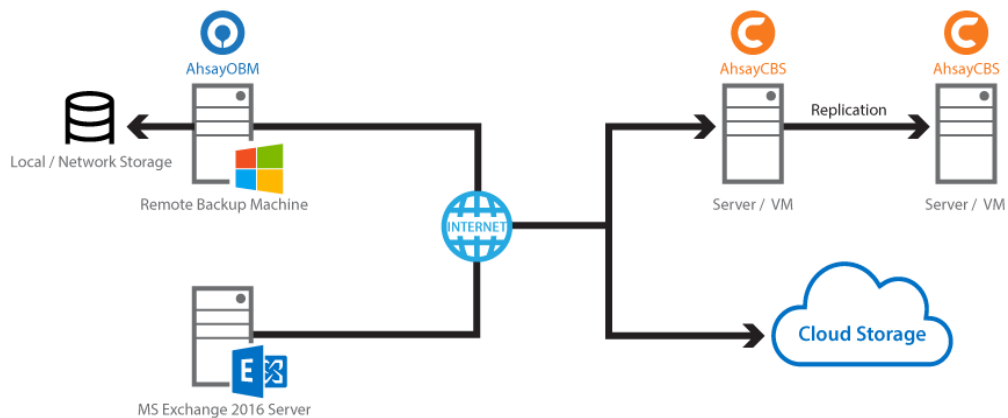

Below is the steps of backup process.

1. Log in to AhsayOBM.
2. Click the Backup icon on the main interface of AhsayOBM.



3. Select the backup set which you would like to start a backup for.

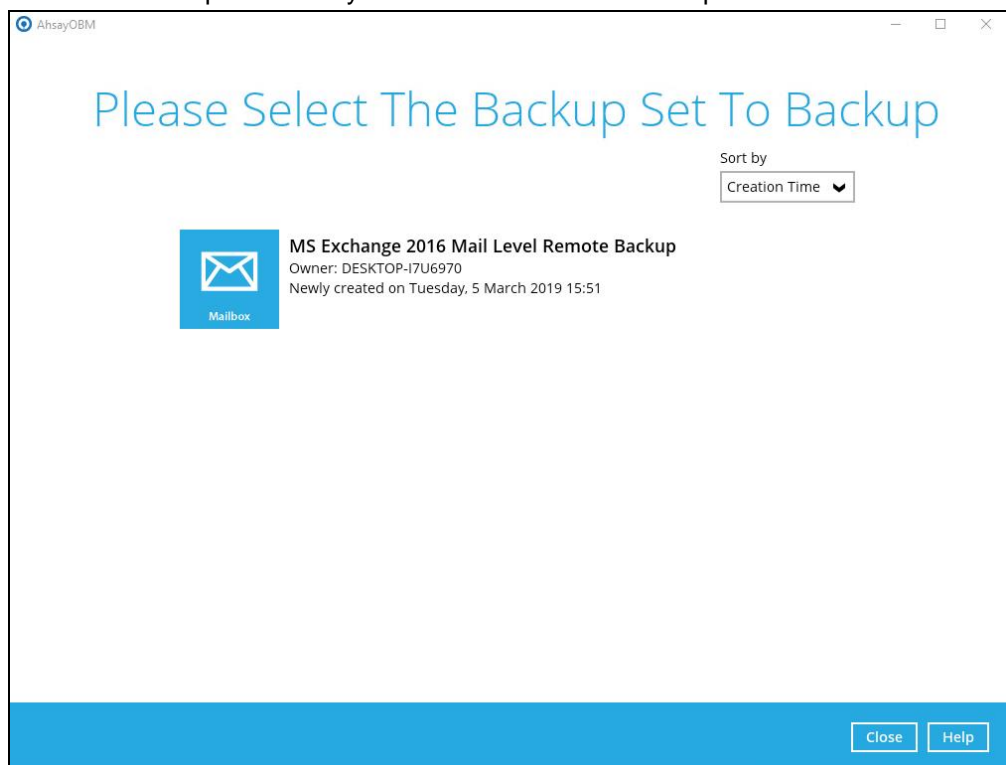

If you would like to modify the In-File Delta type, Destinations and Retention Policy settings, click **Show advanced option**.

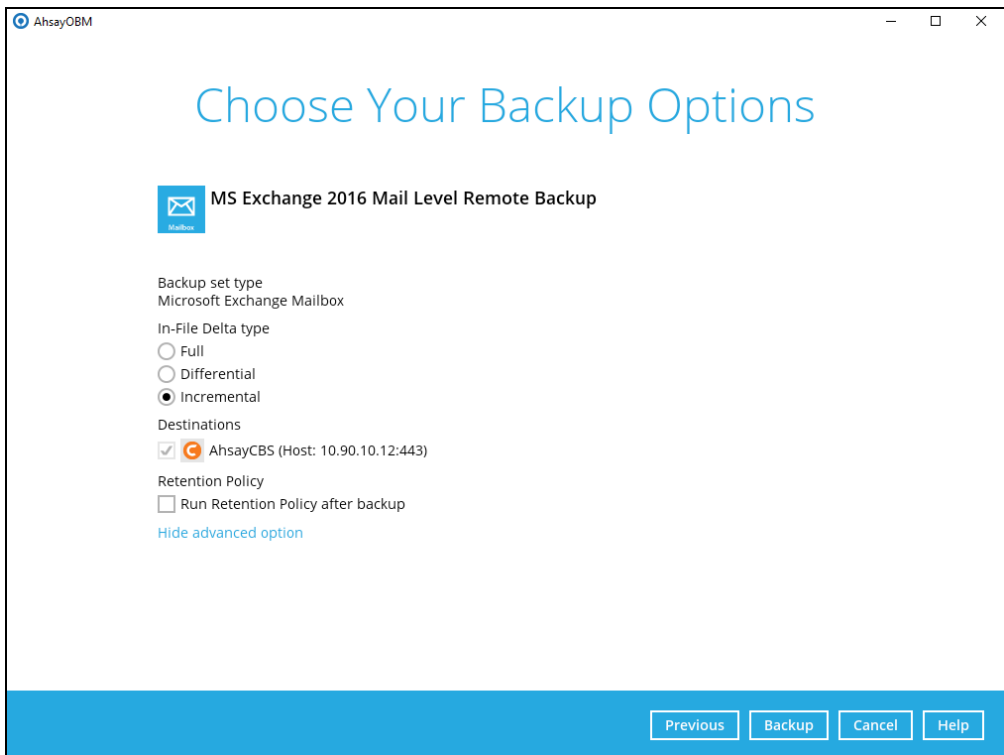
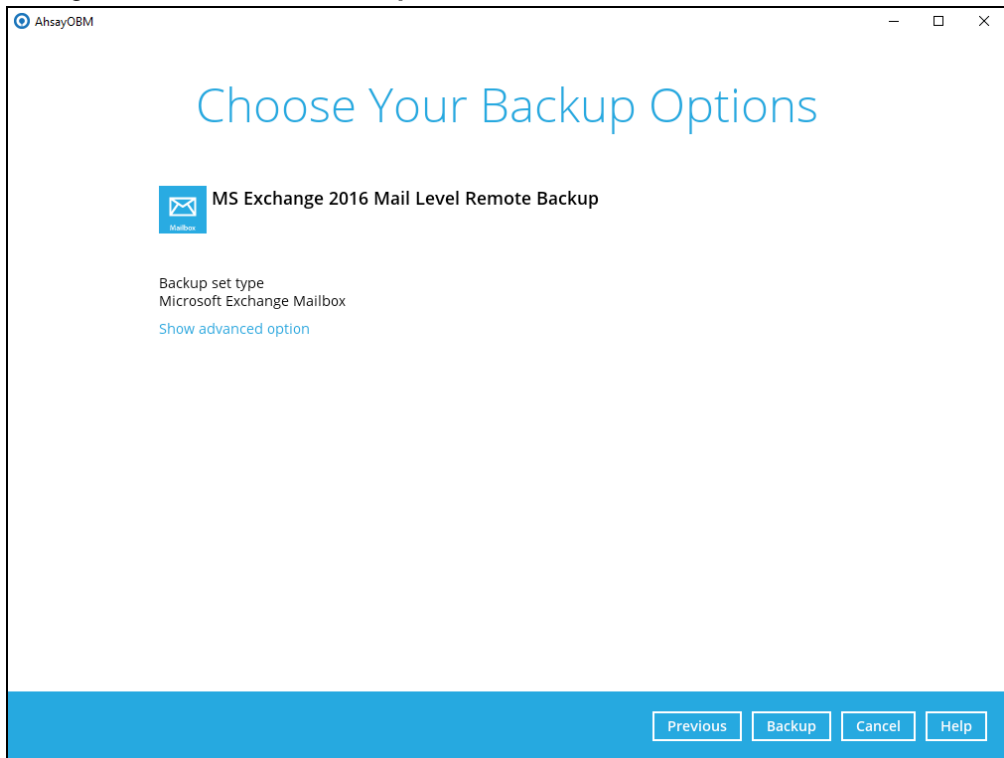

4. Click **Backup** to start the backup.

6.1.3 Restore Mail Level Backup

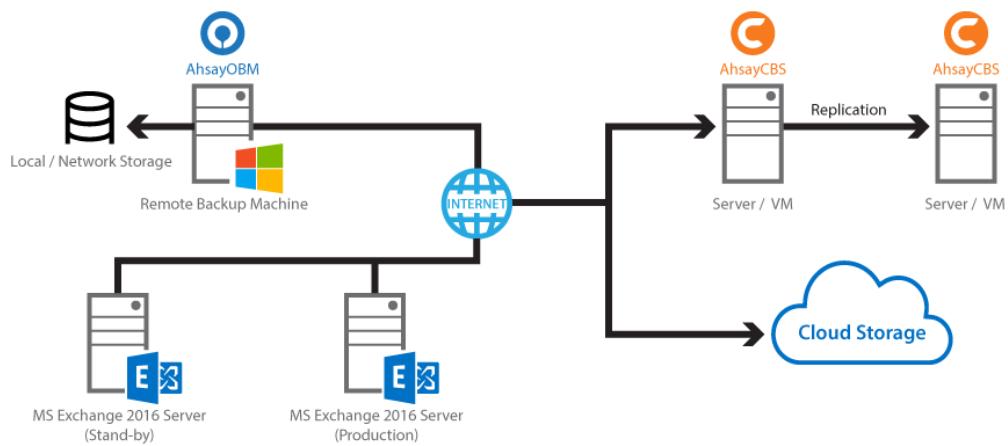

Below are the steps of the restore process.

1. In the AhsayOBM main interface, click the **Restore** icon.

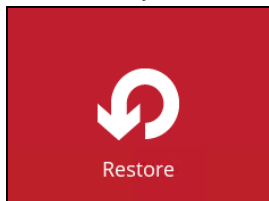

2. Select the backup set that you would like to restore mail from.

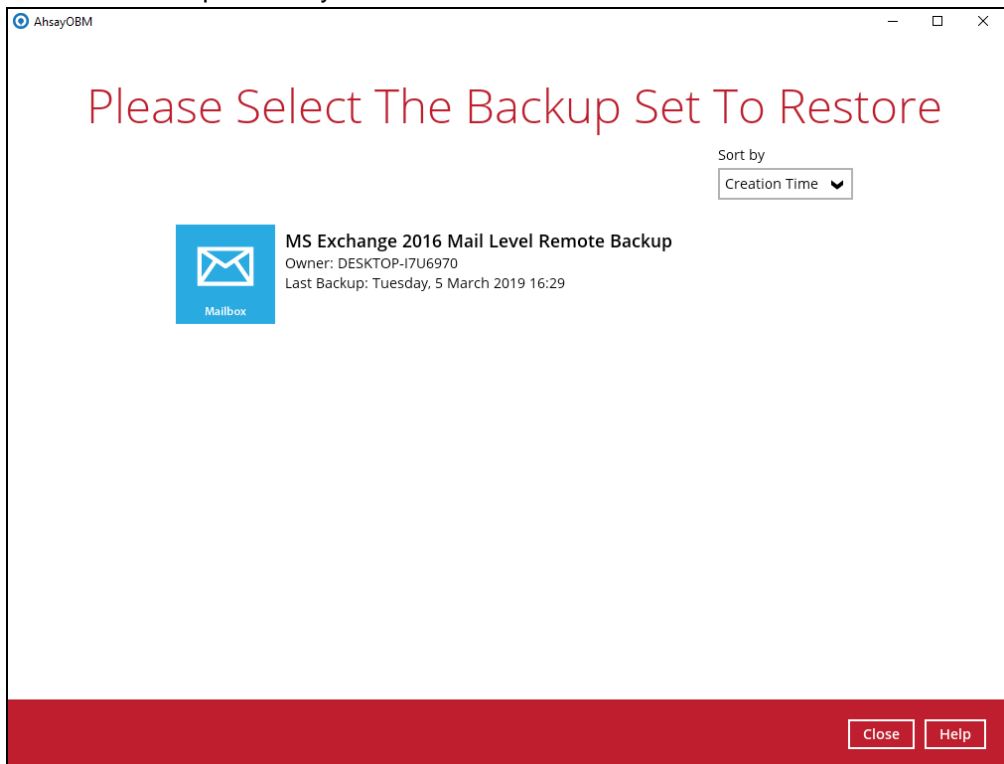

3. Select the backup destination that contains the mail(s) that you would like to restore.

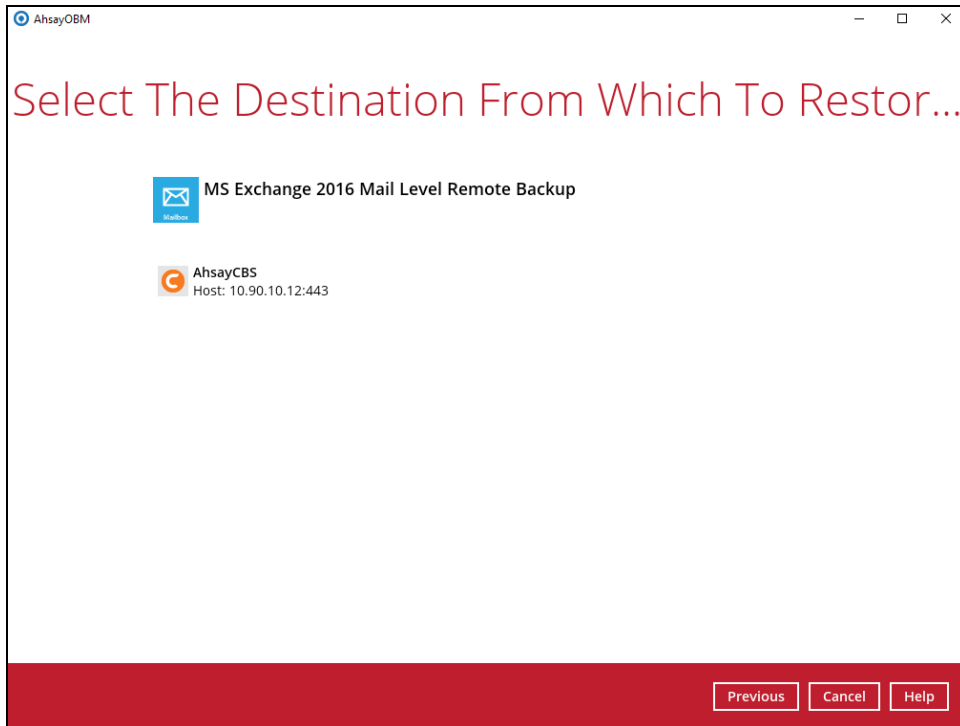

4. Click to expand the menu tree to select which mailbox to restore. You can also select mail item(s) from a specific backup job or all mail items that you have backed up to restore. Click **Next** to proceed.

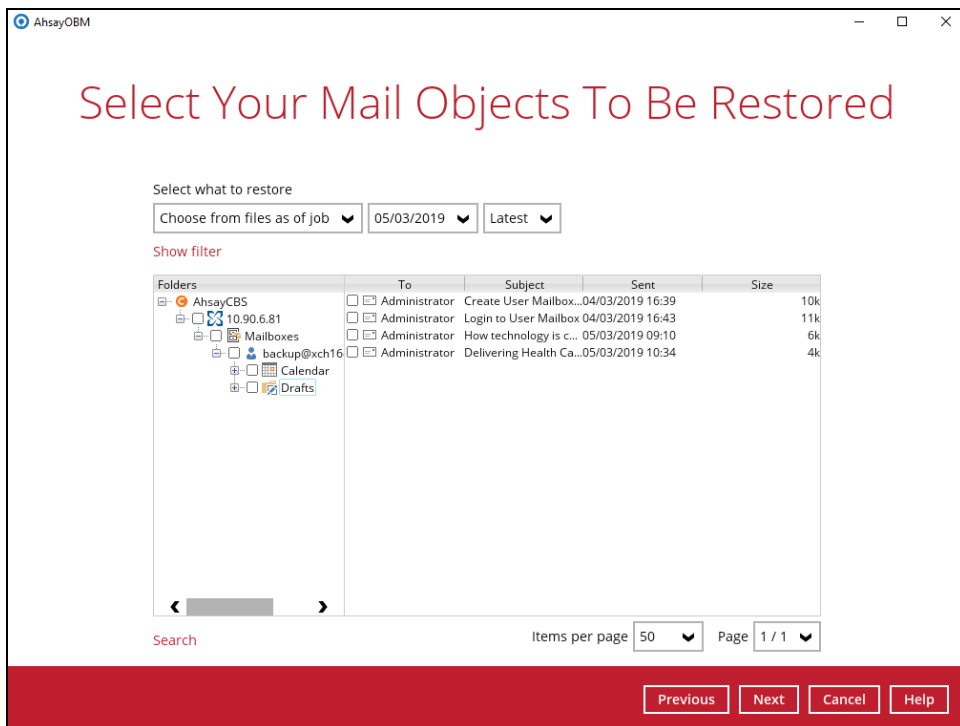

5. Select to restore the mail to their Original location, Alternate location or to an Alternate host.



Restore to Original Location

Select the **Original location** option. If you want to modify the Verify checksum of in-file delta files setting, click the **Show advanced option**. Press **Next** to proceed.

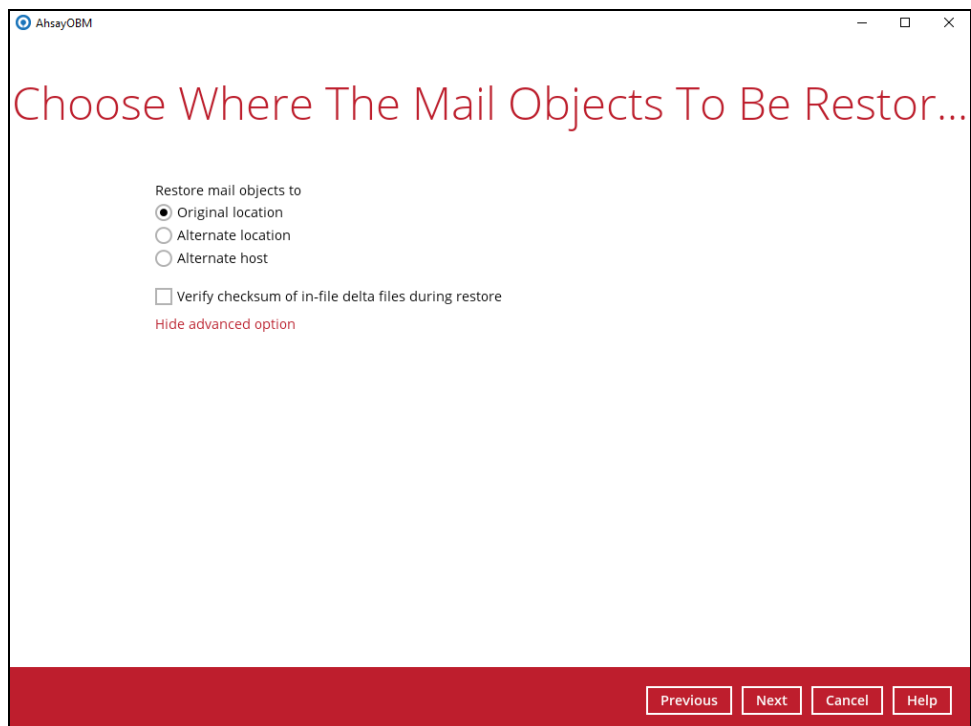
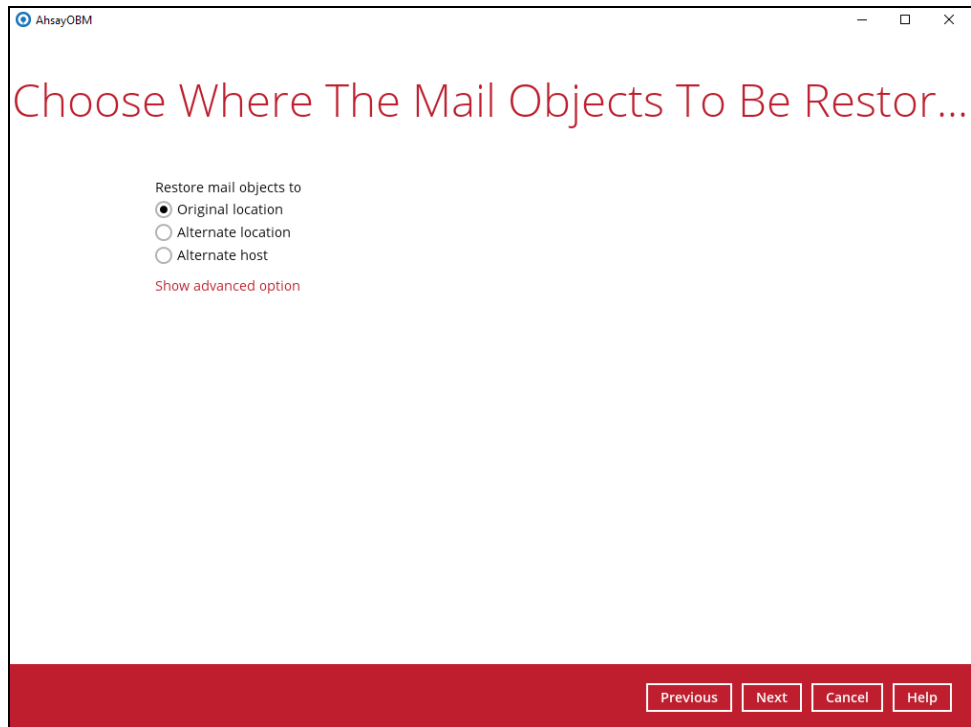

Restore to Alternate Location

You can choose to restore mailbox item(s) to another mailbox in the same Exchange server. Select the **Alternate location** option. If you would like to

modify the Verify checksum of in-file delta files setting, click **Show advanced option** then press **Next**.

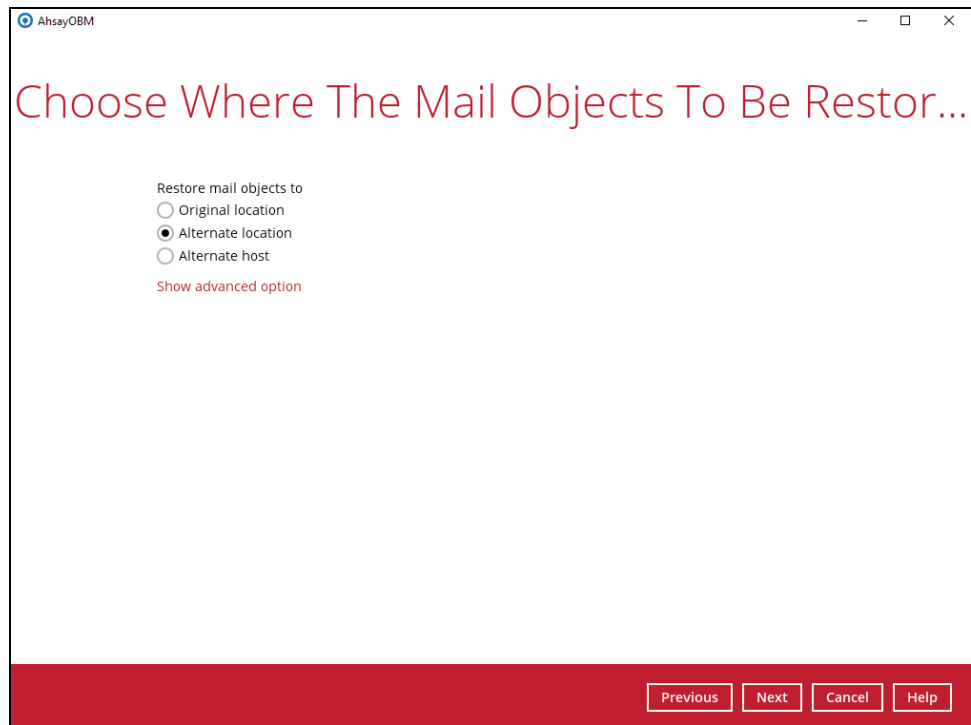

The screenshot shows a dialog box titled "Choose Where The Mail Objects To Be Restor...". It contains three radio button options: "Original location", "Alternate location" (which is selected), and "Alternate host". Below these options is a link labeled "Show advanced option". At the bottom right, there are four buttons: "Previous", "Next", "Cancel", and "Help".

Select the desired mailbox destination, then press **Next** to proceed.

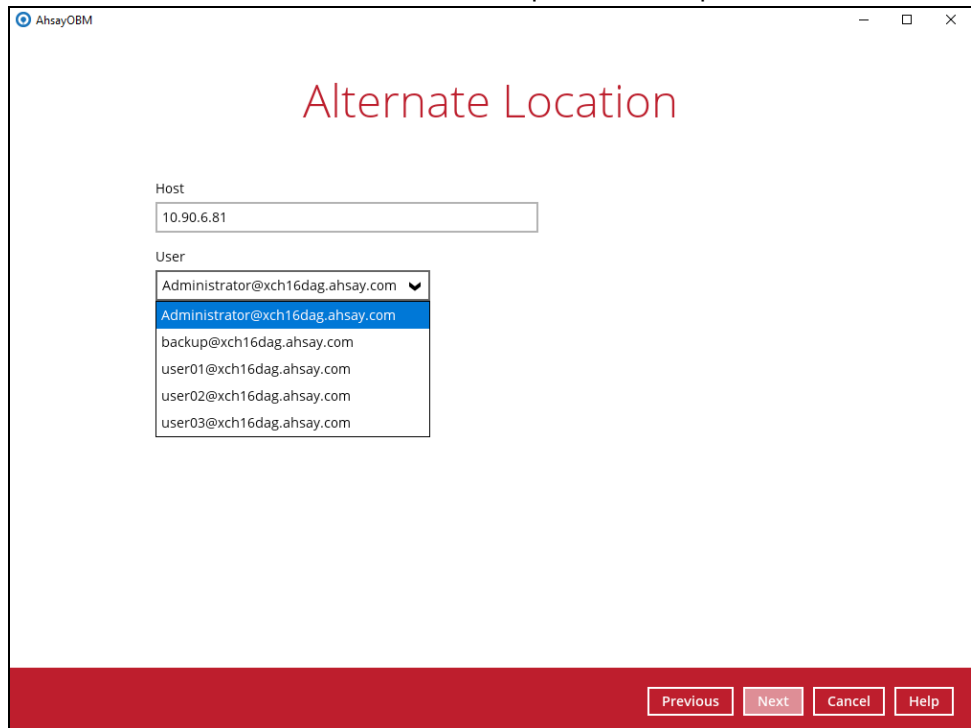

The screenshot shows a dialog box titled "Alternate Location". It has a "Host" text input field containing "10.90.6.81". Below it is a "User" dropdown menu with a list of email addresses: "Administrator@xch16dag.ahsay.com" (selected), "backup@xch16dag.ahsay.com", "user01@xch16dag.ahsay.com", "user02@xch16dag.ahsay.com", and "user03@xch16dag.ahsay.com". At the bottom right, there are four buttons: "Previous", "Next", "Cancel", and "Help".

Restore to Alternate Host

You can choose to restore mailbox item(s) to another mailbox in a different Exchange server. Select the **Alternate host** option and enter the host, username and password. If you will access the internet through proxy, check the box beside it and set the configuration for the proxy server and click **Save**. If you would like

to modify the Verify checksum of in-file delta files setting, click **Show advanced option**.

Choose Where The Mail Objects To Be Restor...

Restore mail objects to

- Original location
- Alternate location
- Alternate host

Host
10.90.6.81

Username
backup

Password
•••••

Access the Internet through proxy

Test

Show advanced option

Previous Next Cancel Help

Proxy (HTTP)

IP address Port

Login ID

Password
•••••

Test connection

Save Cancel

Select the desired mailbox destination, then press **Next** to proceed.

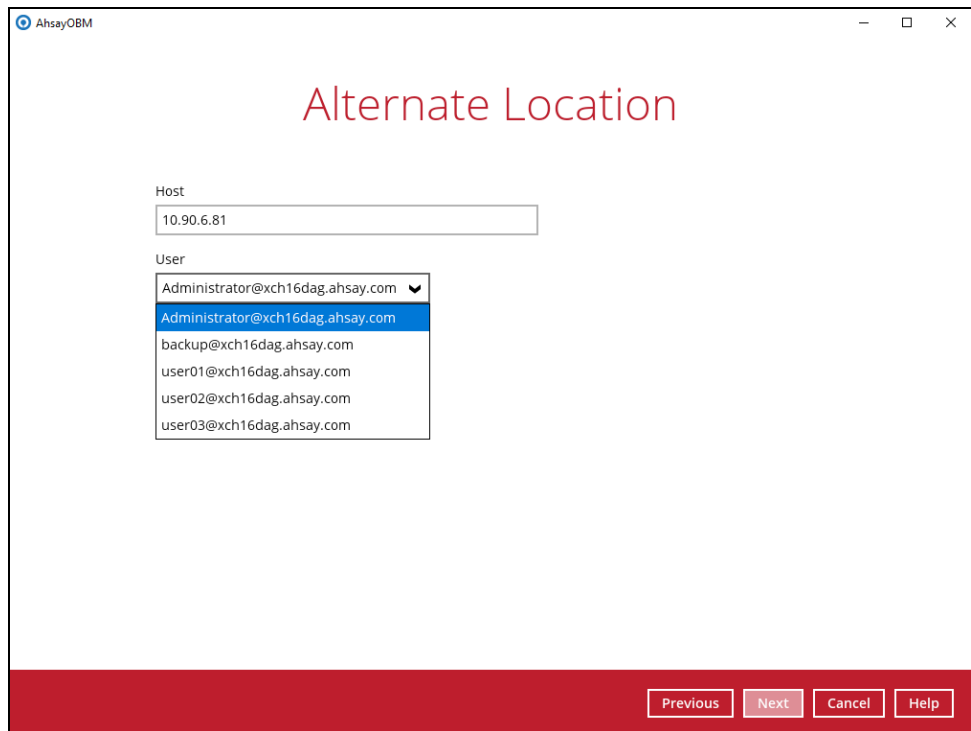

Please refer to the [Limitation](#) part to check the limitation of restore process.

6. Select the temporary directory for storing temporary files, such as delta files when they are being merged, click **Restore** to start the restoration.

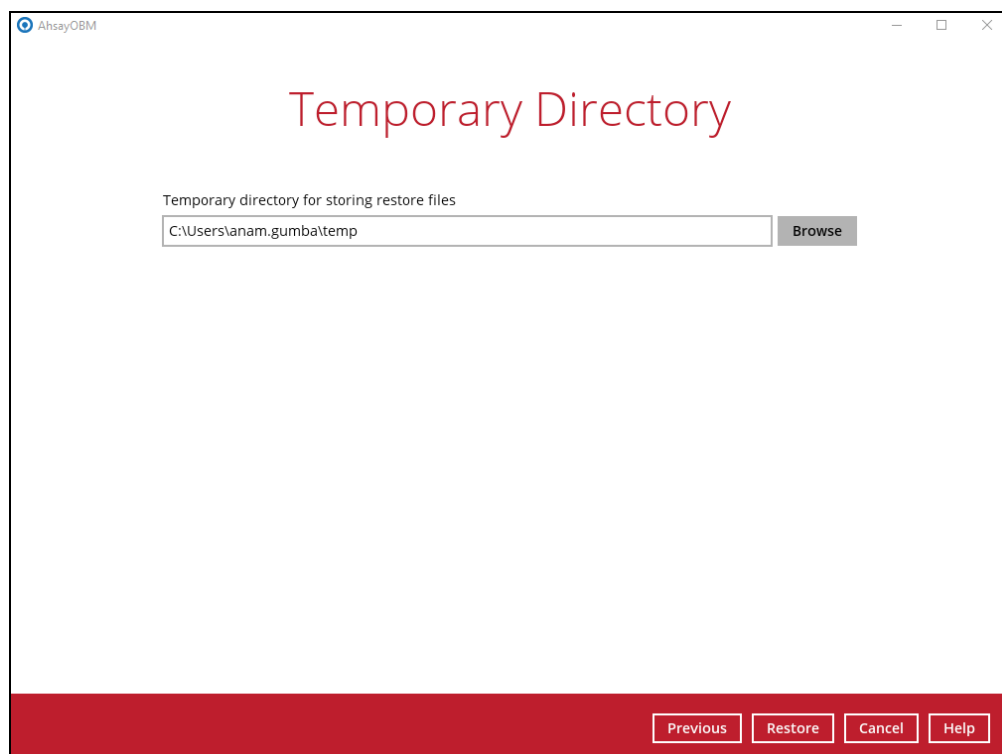

7. The following screen with the text **Restore Completed Successfully** shows when the restoration is completed.

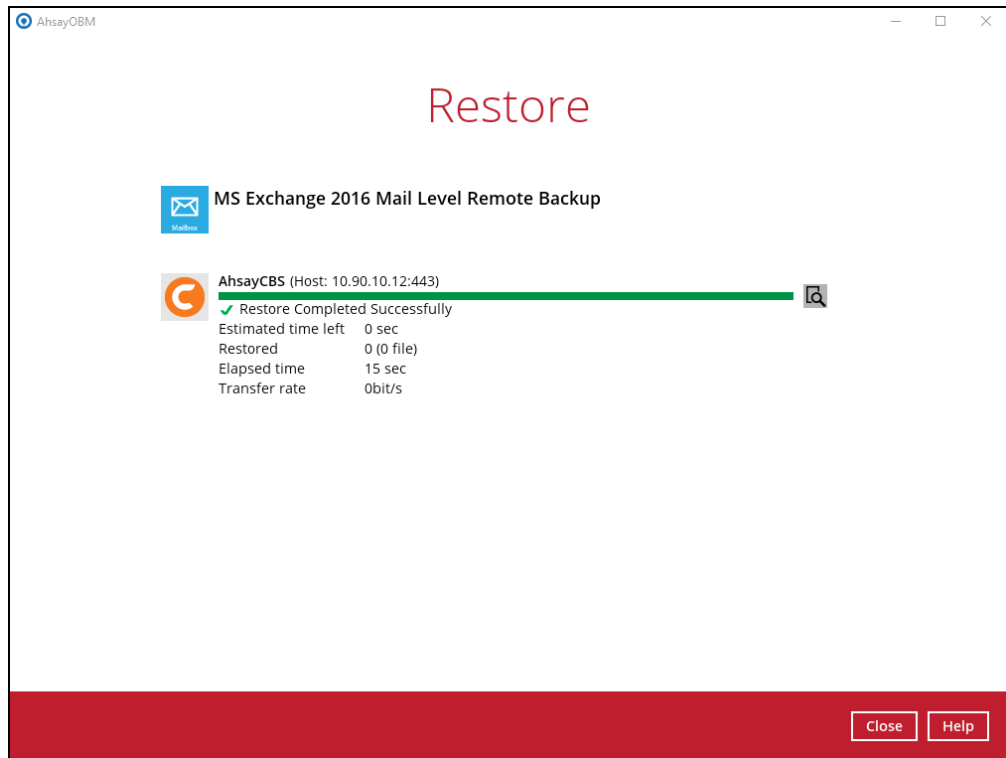

6.2 Database Availability Group (DAG) Backup Option

6.2.1 Create Mail Level Backup Set

1. Click the **Backup Sets** icon on the main interface of AhsayOBM.



2. Create a new backup set by clicking the “+” icon next to **Add new backup set**.
3. Select the Backup set type as **MS Exchange Mail Level Backup**.

- ⊙ Name your new backup set.
- ⊙ Select from the following version:
 - Microsoft Exchange Server 2013
 - Microsoft Exchange Server 2016
 - Microsoft Exchange Server 2019
 - Microsoft Exchange Server 2013 (DAG)
 - Microsoft Exchange Server 2016 (DAG)
 - Microsoft Exchange Server 2019 (DAG)

As AhsayOBM is not installed directly on the MS Exchange 2016 / 2019 server, it cannot automatically detect the MS Exchange version. Therefore, the MS Exchange version must be selected manually.

- ⊙ Enter the hostname of Exchange server.
- ⊙ Enter the username and password of the Windows user account used for backup.
- ⊙ Check the “Access the Internet through proxy” if required.
- ⊙ Click the **Test** button to verify the login details.
- ⊙ Then click **Next** to proceed.

AhsayOBM

Create Backup Set

Name
MS Backup 2019 Mail Level Backup (DAG)

Backup set type
MS Exchange Mail Level Backup

Version
Microsoft Exchange Server 2007
Microsoft Exchange Server 2010
Microsoft Exchange Server 2013
Microsoft Exchange Server 2016
Microsoft Exchange Server 2019
Microsoft Exchange Server 2010 (DAG)
Microsoft Exchange Server 2013 (DAG)
Microsoft Exchange Server 2016 (DAG)

Next Cancel Help

AhsayOBM

Create Backup Set

Name
MS Exchange 2019 Mail Level Remote Backup (DAG)

Backup set type
MS Exchange Mail Level Backup

Version
Microsoft Exchange Server 2019 (DAG)

Host (DAG Member Server)
IP address of DAG Member Server X
IP address of DAG Member Server X
Add

Username
username

Password
.....

Access the Internet through proxy

Test

Next Cancel Help

- In the **Backup Source** menu, select the mailboxes or public folders for backup. Fifty (50) users will be displayed by default. If the MS Exchange Server account consists of more than fifty (50) users or above, click the **show next 50** button to display the next users. You can expand the mailbox or public folder to select which mail folder to back up by clicking the **[+]** button. You can also click **Show mails** to select an individual mail to back up. Once done, click **Next** to proceed.

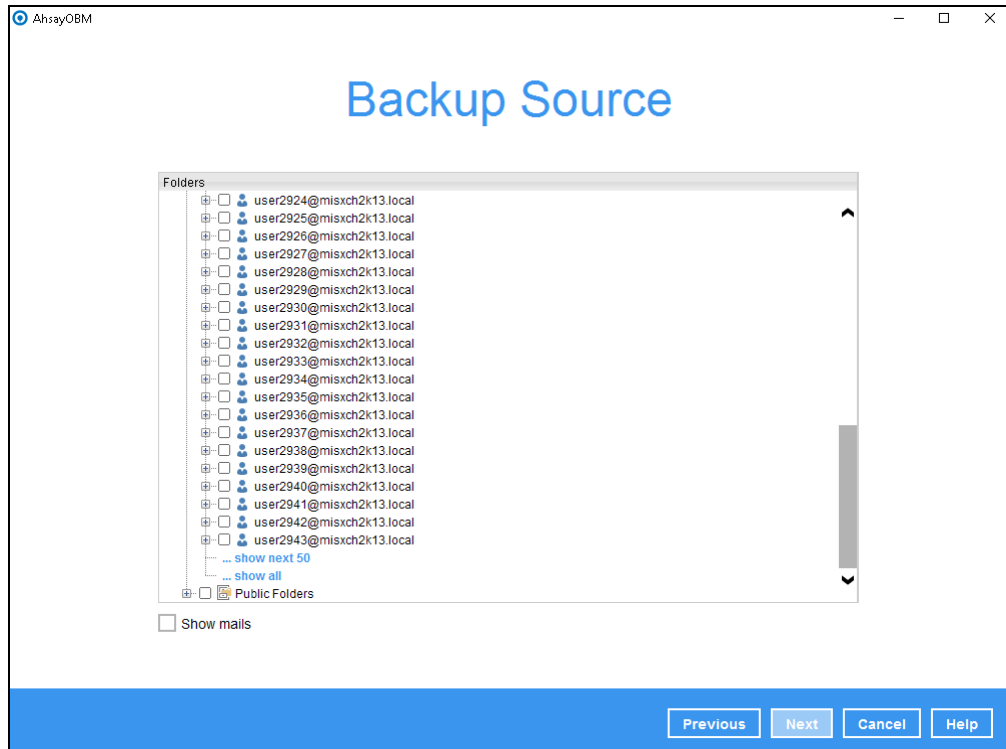

5. In the Schedule menu, you can configure a backup schedule for backup job to run automatically at your specified time interval. By default, the **Run scheduled backup for this backup set** option is disabled. Enable it, then click the “+” icon next to **Add new schedule**. Click **Next** to proceed when you are done setting.

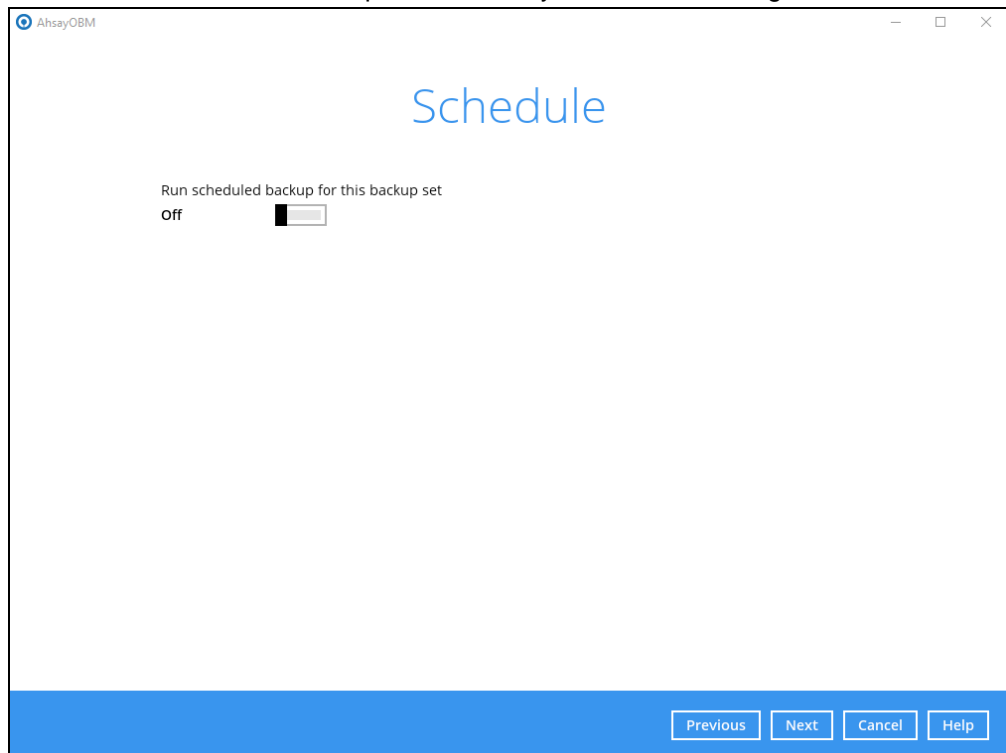

6. In the Destination menu, select a backup destination where the backup mail will be stored. Click the “+” icon next to **Add new storage destination / destination pool**.

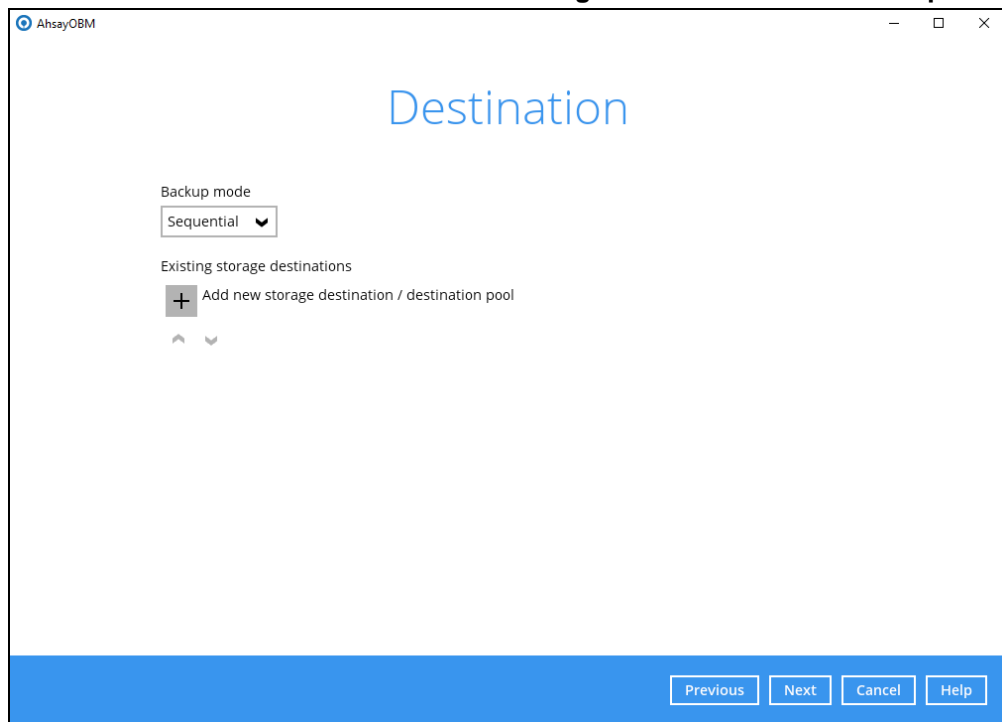

7. Select the destination storage, then click **OK** to proceed.

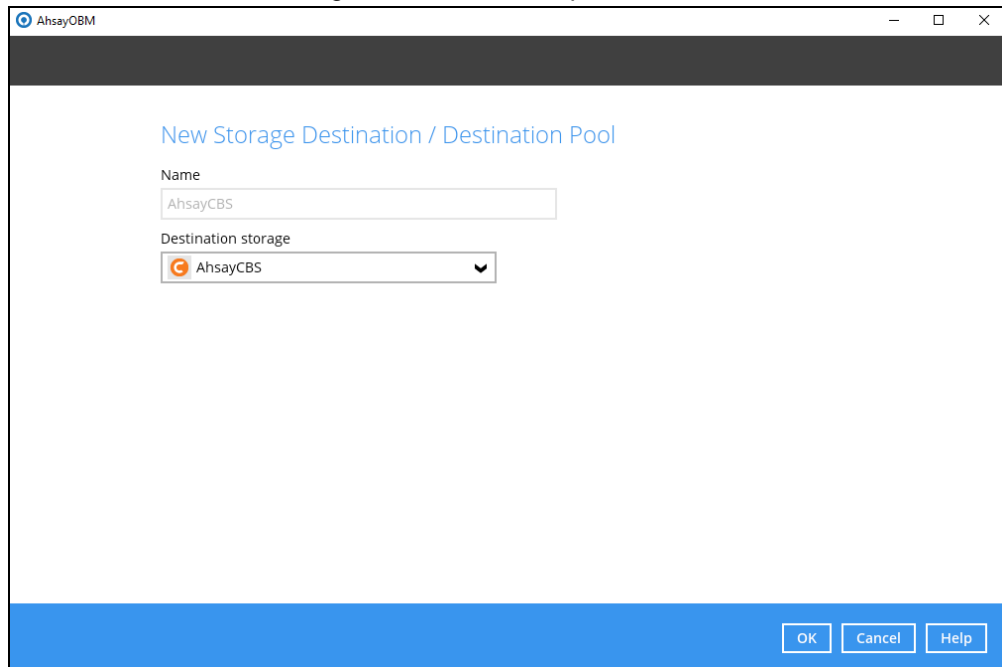

8. Click **Next** on the Destination menu page to proceed.

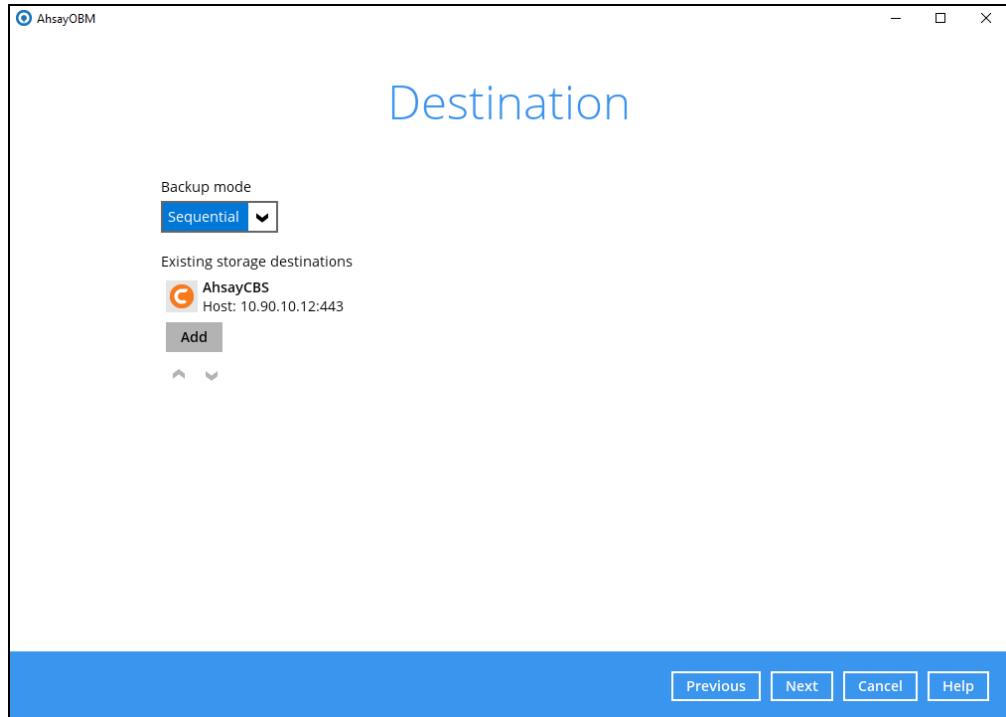

9. In the Encryption window, the default **Encrypt Backup Data** option is enabled with an encryption key preset by the system which provides the most secure protection.

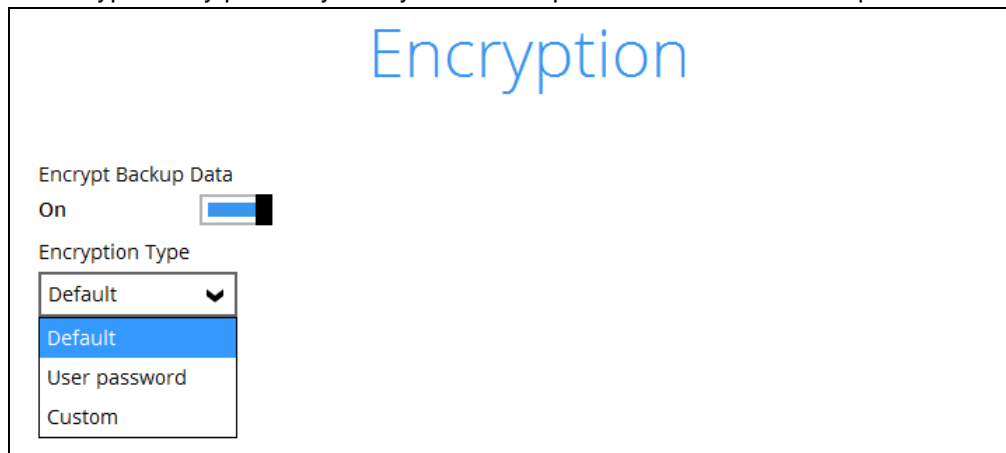

10. You can choose from one of the following three Encryption Type options:
- **Default** – an encryption key with 44 alpha numeric characters will be randomly generated by the system
 - **User password** – the encryption key will be the same as the login password of your AhsayOBM at the time when this backup set is created. Please be reminded that if you change the AhsayOBM login password later, the encryption keys of the backup sets previously created with this encryption type will remain unchanged.

- **Custom** – you can customize your encryption key, where you can set your own algorithm, encryption key, method and key length.

Encryption

Encrypt Backup Data
On

Encryption Type
Custom ▼

Algorithm
AES ▼

Encryption key

Re-enter encryption key

Method
 ECB CBC

Key length
 128-bit 256-bit

NOTE

For best practice on managing your encryption key, refer to the following article: [Best Practices for Managing Encryption Key on AhsayOBM or AhsayACB.](#)

Click **Next** when you are done setting.

11. If you have enabled the Encryption Key feature in the previous step, the following pop-up window shows, no matter which encryption type you have selected.

Encryption

Encrypt Backup Data
On

Encryption Type
Default ▼

You are advised to write this encryption key down on paper and keep it in a safe place. You will need it when you need to restore your files later. Please confirm that you have done so.

Unmask encryption key

Copy to clipboard Confirm

The pop-up window has the following three options to choose from:

- **Unmask encryption key** – The encryption key is masked by default. Click this option to show the encryption key.

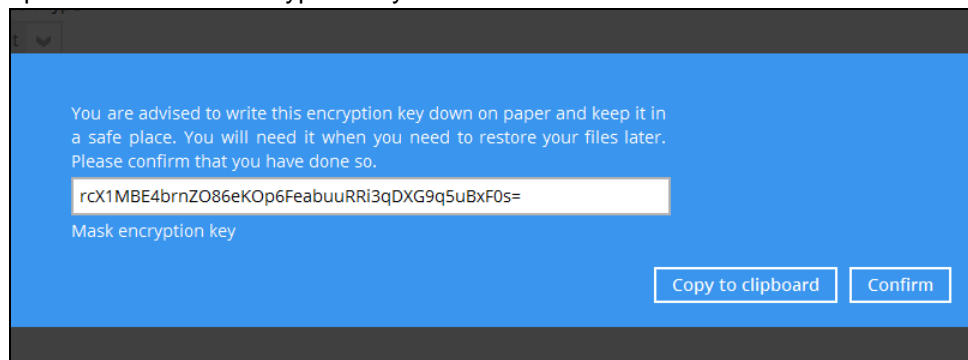

- **Copy to clipboard** – Click to copy the encryption key, then you can paste it in another location of your choice.
- **Confirm** – Click to exit this pop-up window and proceed to the next step

12. Enter the Windows login credentials for user authentication. Click **Next** to proceed. The User name should be entered in the following format "user@hostname", i.e. administrator@ahsay.com

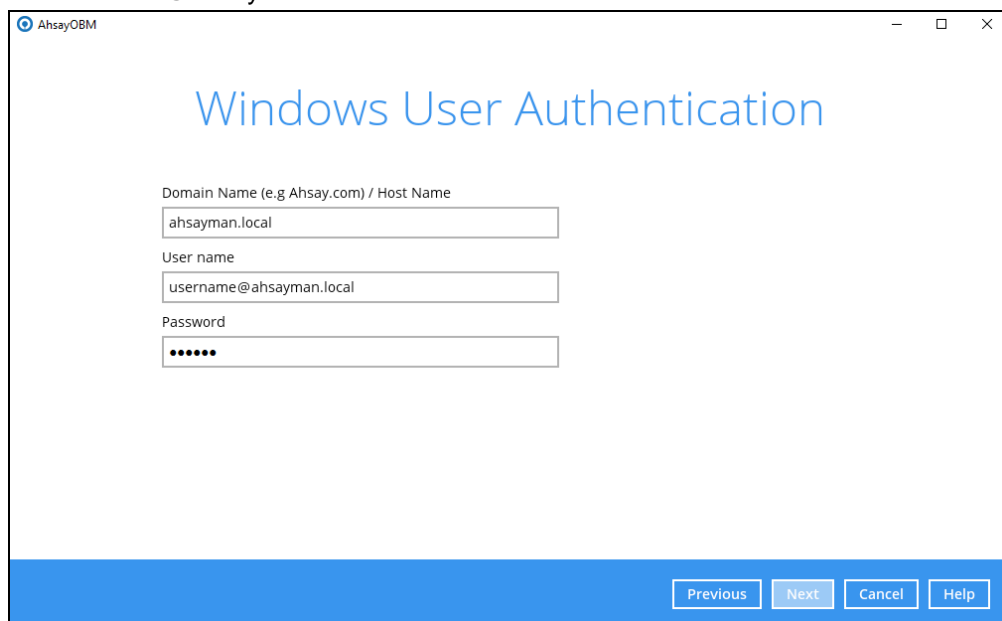

NOTE

The Windows User Authentication interface will show only if scheduled backup is enabled and set successfully.

13. The following screen shows when the new backup set is created successfully.

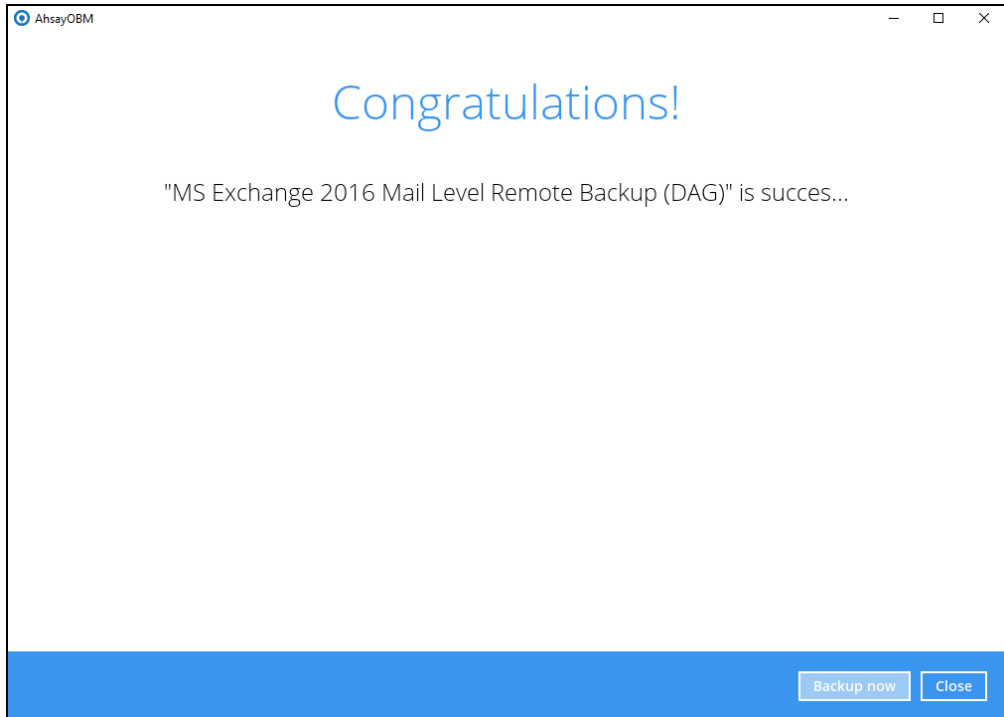

14. Click Backup now to start a backup immediately, or you can run a backup job later by following the instructions in [Run Mail Level Backup Job](#)
15. Based on [Best Practices and Recommendations](#), it is highly recommended to set the **temporary directory** to another location other than Drive C: (e.g. Drive E:). To do this, go to **Backup Sets > Others > Temporary Directory** and click the **Change** button to browse for another location.

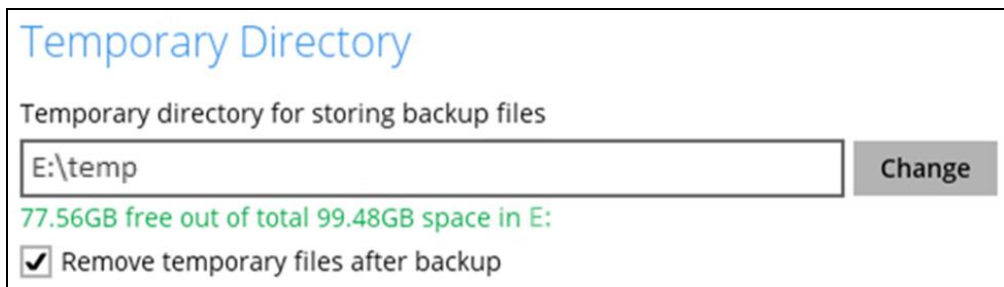

16. Optional: Select your preferred **Compression** type. By default, the compression type is Fast with optimization for local.

Go to **Others > Compressions**, then select from the following:

- No Compression
- Normal
- Fast (Compressed size larger than normal)
- Fast with optimization for local

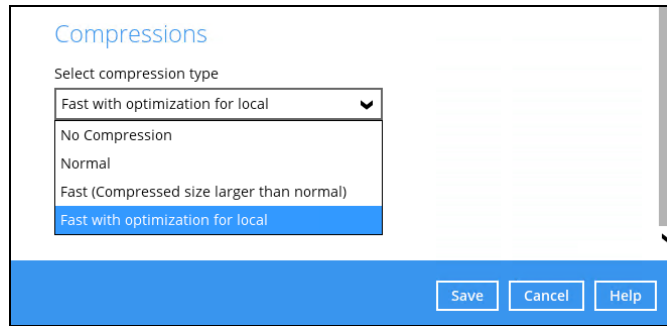

6.2.2 Run Mail Level Backup Job

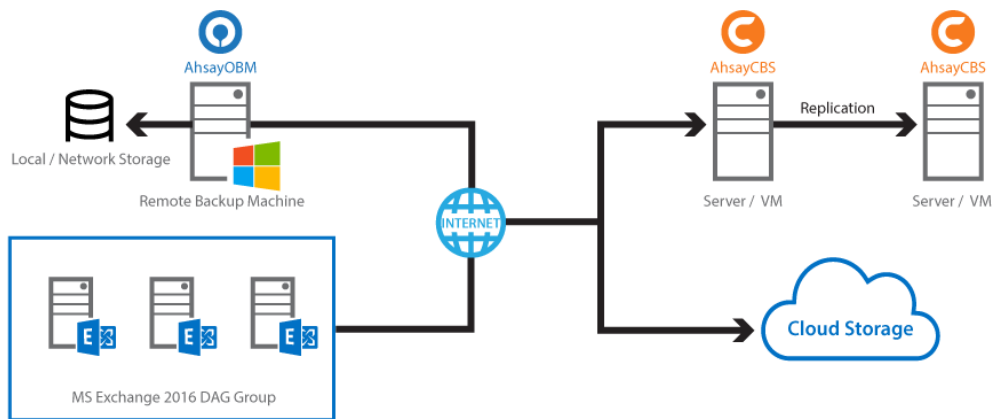

Below are the steps of the backup process.

1. Log in to AhsayOBM.
2. Click the Backup icon on the main interface of AhsayOBM.



3. Select the backup set which you would like to start a backup for.

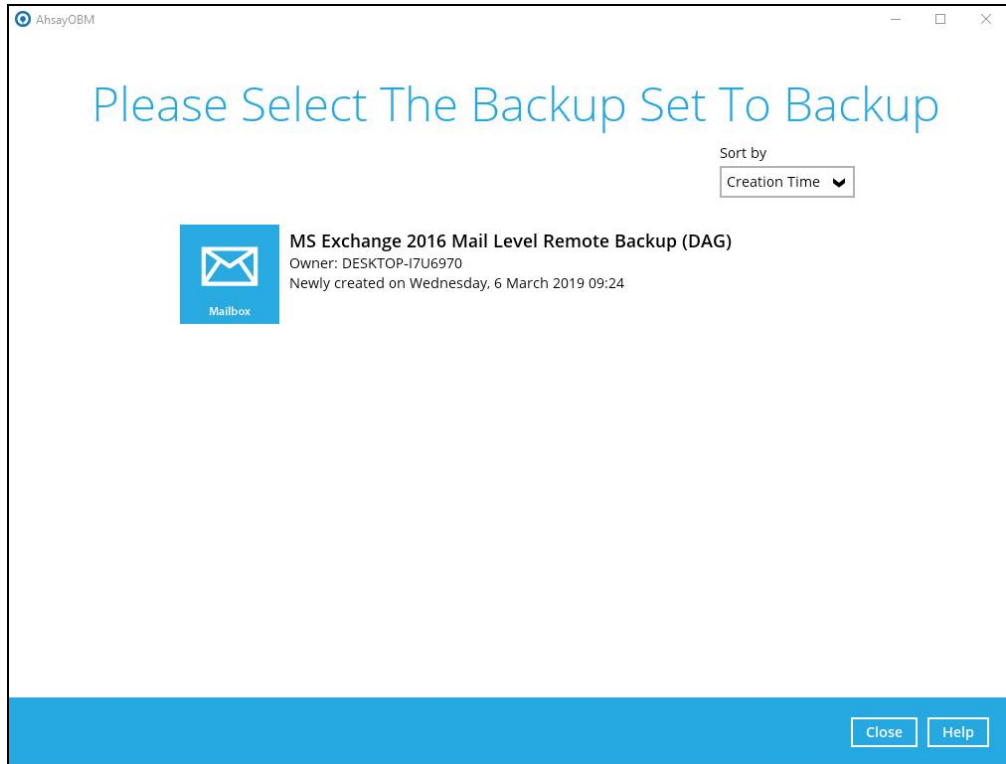

4. If you would like to modify the In-File Delta type, Destinations and Retention Policy settings, click **Show advanced option**.

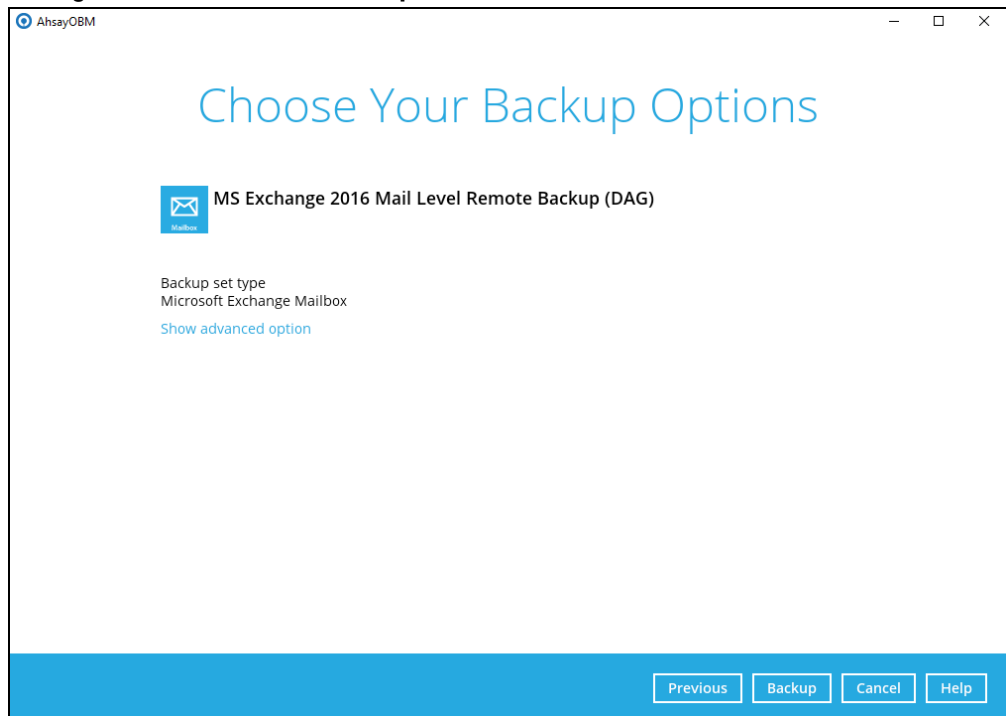

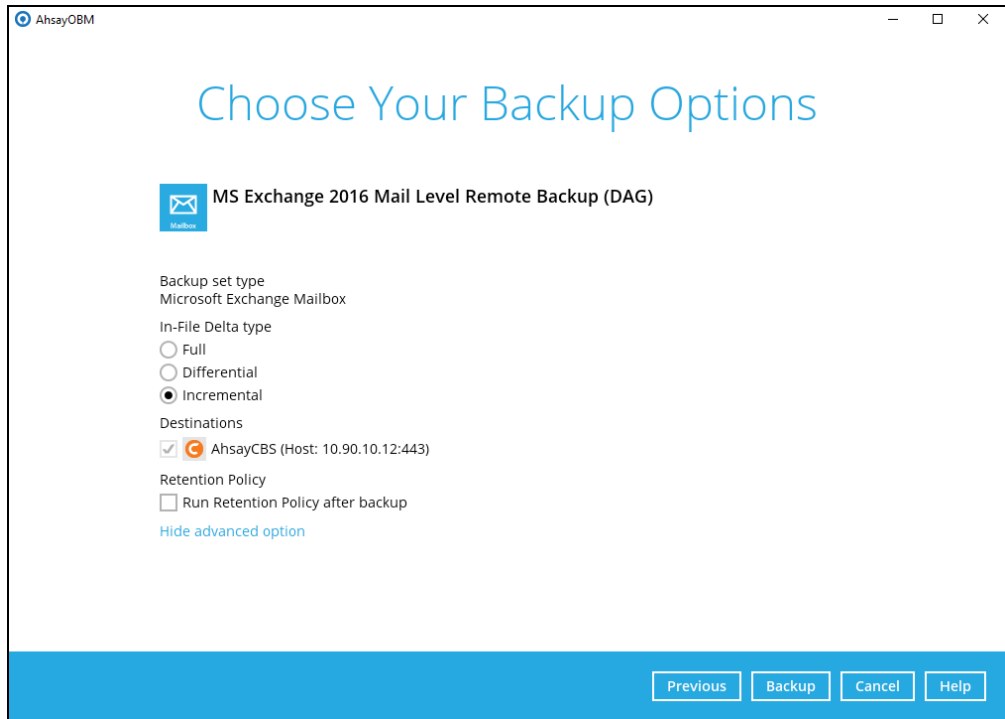

5. Click **Backup** to start the backup job.

6.2.3 Restore Mail Level Backup

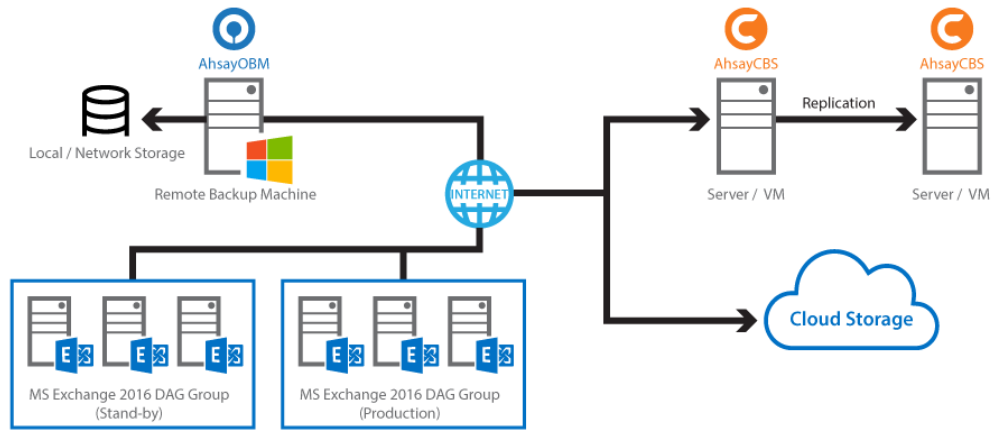

Below are the steps of the restore process.

1. In the AhsayOBM main interface, click the **Restore** icon.

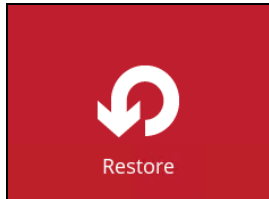

2. Select the backup set that you would like to restore mail from.

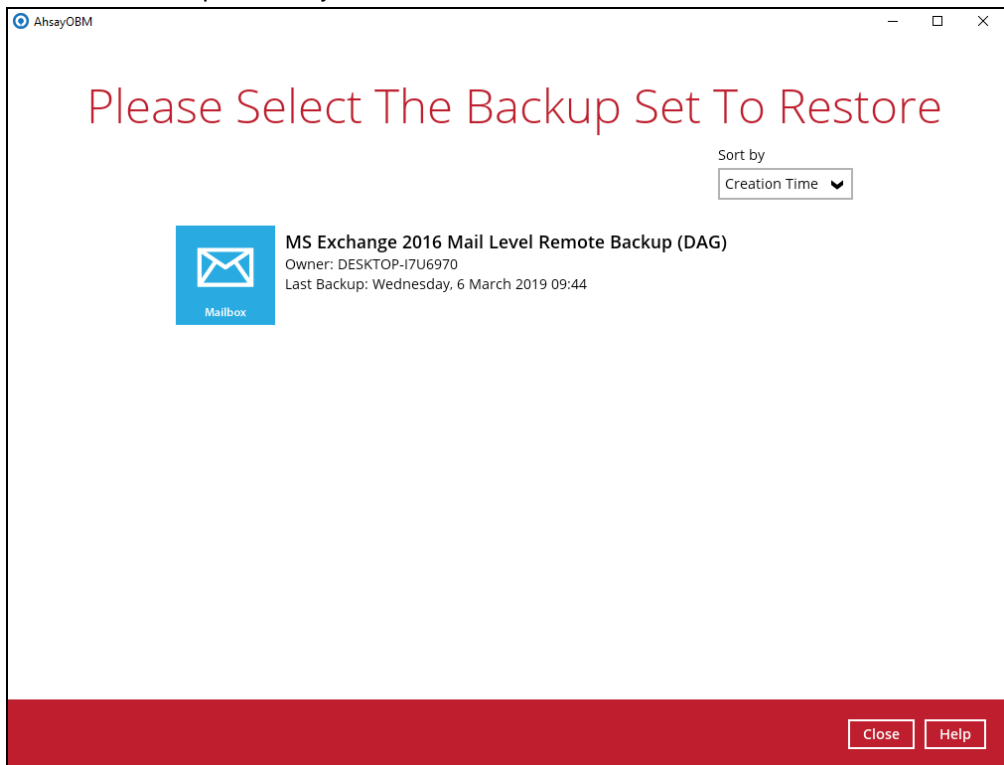

3. Select the backup destination that contains the mail(s) that you would like to restore.



4. Click to expand the menu tree to select which mailbox to restore. You can also select mail item(s) from a specific backup job or all mail items that you have backed up to restore. Click **Next** to proceed.

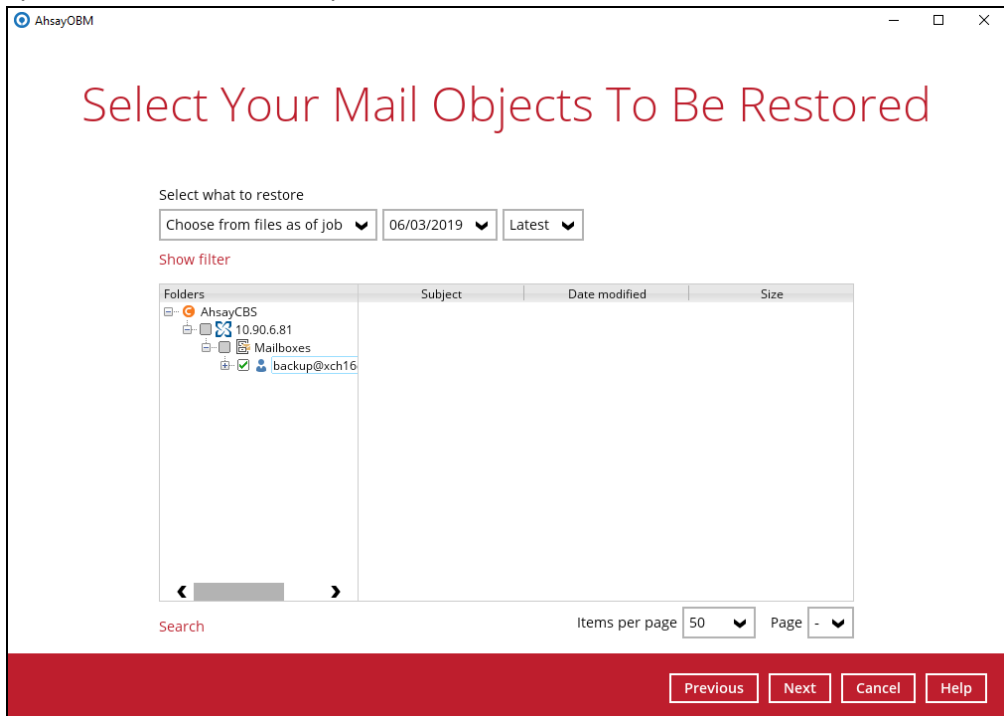

5. Select to restore the mail to their Original location, Alternate location or to an Alternate host.

• **Restore to Original Location**

Select the **Original location** option. If you want to modify the Verify checksum of in-file delta files setting, click **Show advanced option**. Press **Next** to proceed.

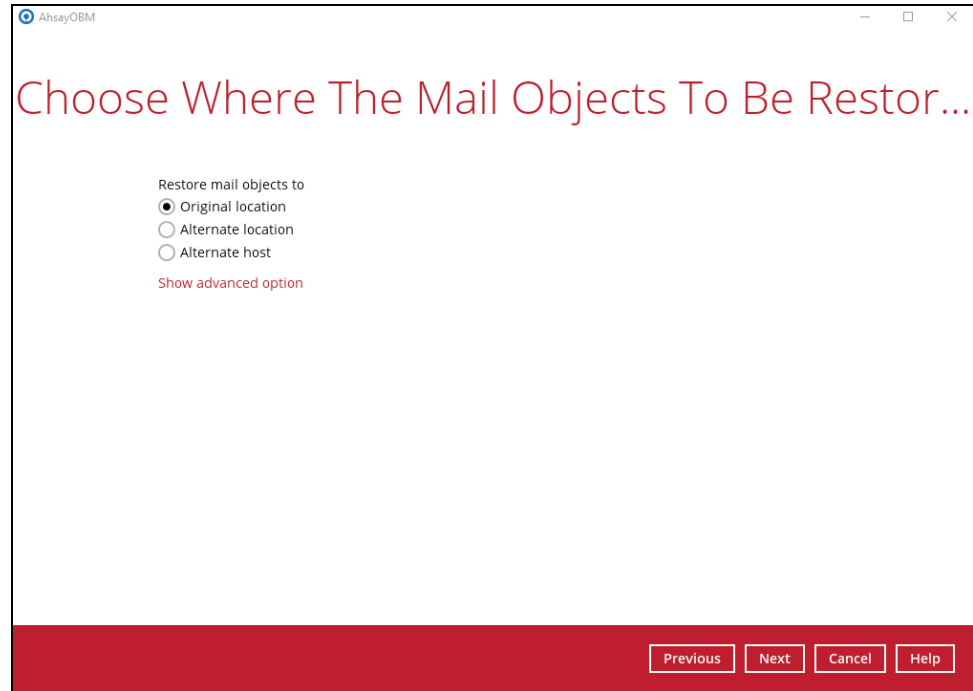

• **Restore to Alternate Location**

You can choose to restore mailbox item(s) to another mailbox in the same Exchange server. Select the **Alternate location** option. If you want to modify the Verify checksum of in-file delta files setting, click **Show advanced option** and press **Next**. Select the desired mailbox destination, then press **Next** to proceed.

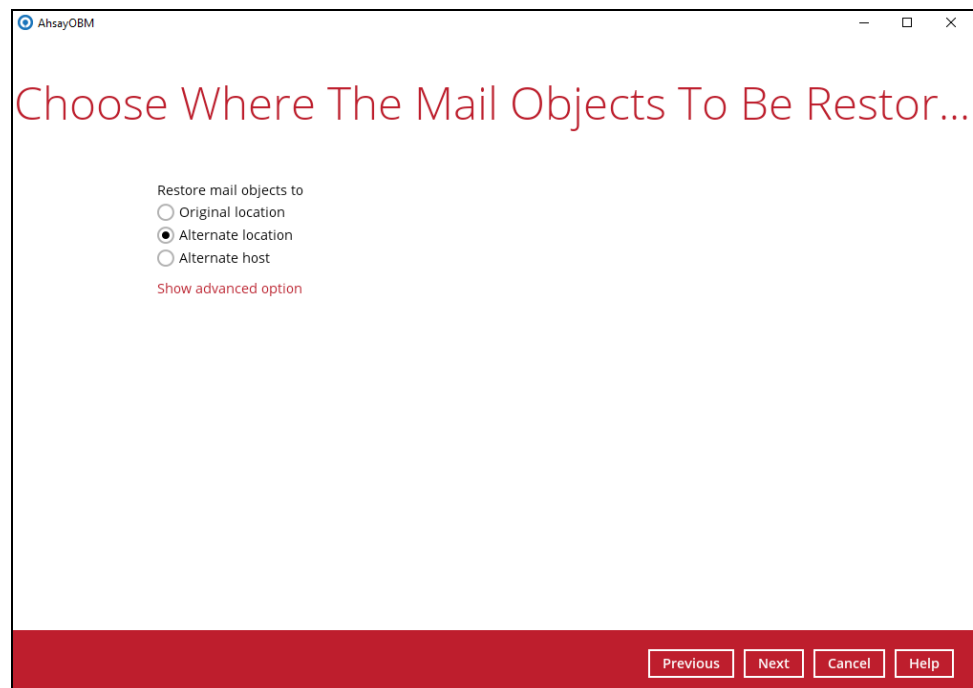

⦿ Restore to Alternate Host

You can choose to restore mailbox item(s) to another mailbox in the same Exchange server. Select the **Alternate host** option and enter the host, username and password. If you will access the internet through proxy, check the box beside it and set the configuration for the proxy server and click **Save**. If you would like to modify the Verify checksum of in-file delta files setting, click **Show advanced option** then press **Next**.

Proxy (HTTP)

IP address Port

Login ID

Password

Select the desired mailbox destination, then press **Next** to proceed.

AhsayOBM

Alternate Location

Host

User

- Administrator@xch16dag.ahsay.com
- Administrator@xch16dag.ahsay.com
- backup@xch16dag.ahsay.com
- user01@xch16dag.ahsay.com
- user02@xch16dag.ahsay.com
- user03@xch16dag.ahsay.com

Please refer to the [Limitation](#) part to check the limitation of restore process.

6. Select the temporary directory for storing temporary files, such as delta files when they are being merged, click **Restore** to start the restoration.

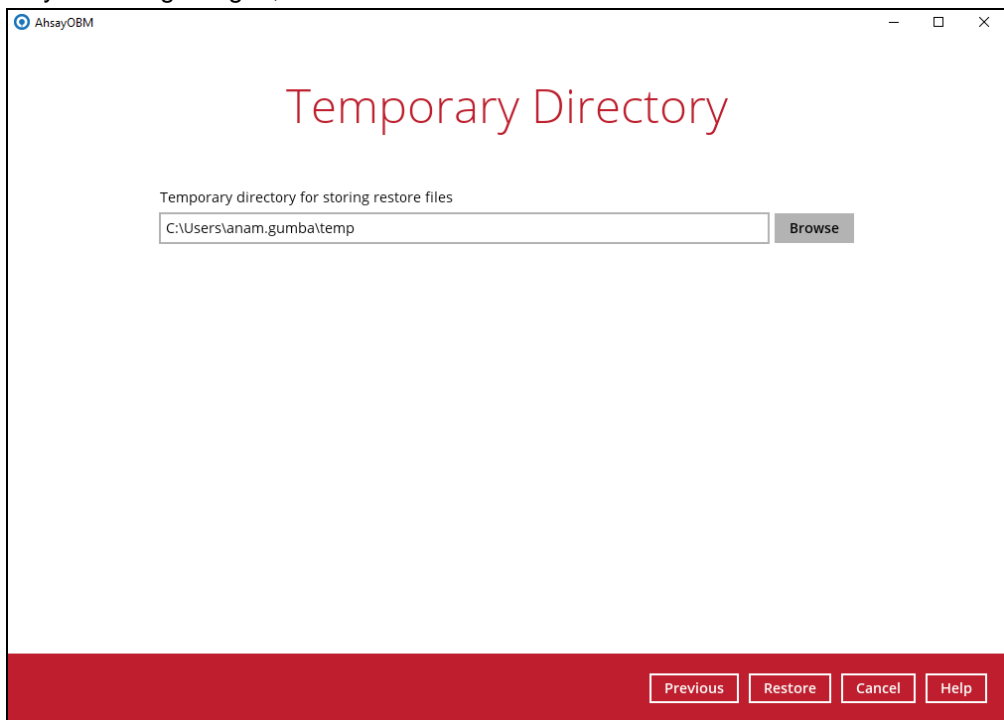

7. The following screen with the text **Restore Completed Successfully** shows when the restoration is completed.

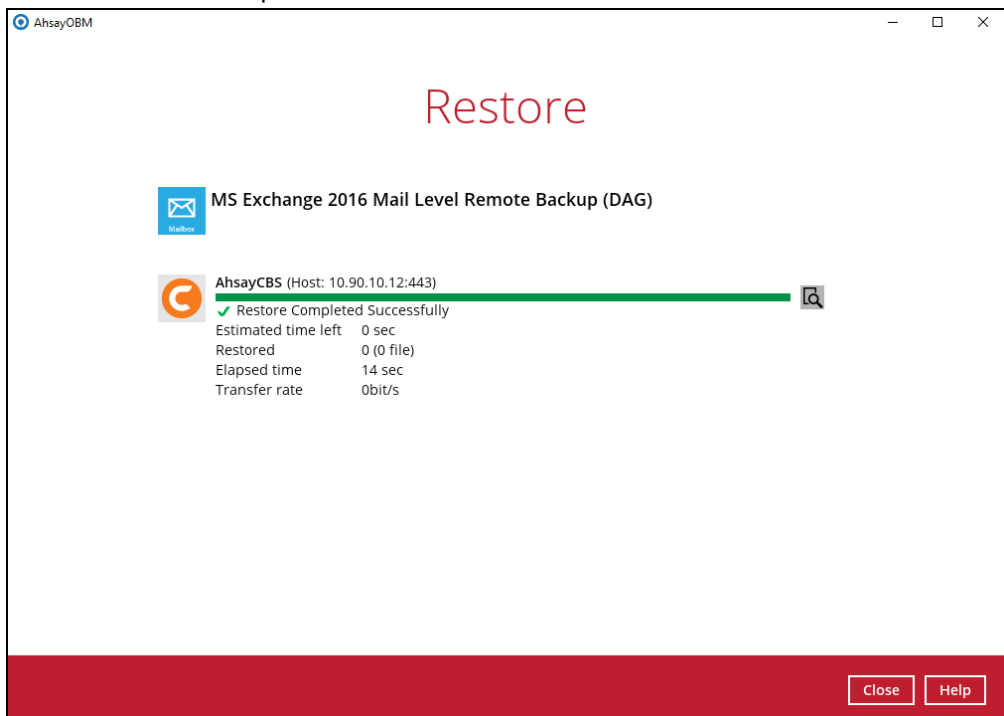

6.3 Configure Backup Schedule for Automated Backup

1. Click the Backup Sets icon on the AhsayOBM main interface.

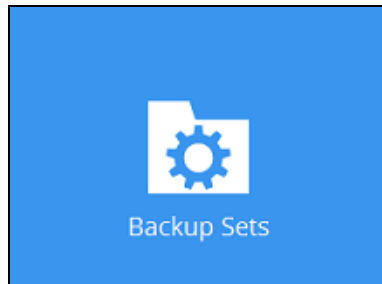

2. All backup sets will be listed. Select the backup set that you would like to create a backup schedule for.
3. Go to the **Backup Schedule** tab. If the **Run scheduled backup for this backup set** option is off, switch it **On**. Existing schedules will be listed if there is any. Click the **Add** button to add a new backup schedule.

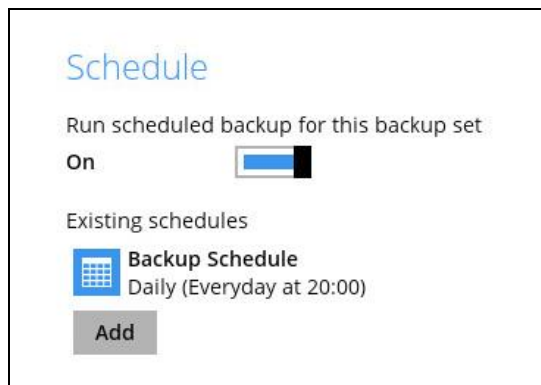

4. The New Backup Schedule window will appear.

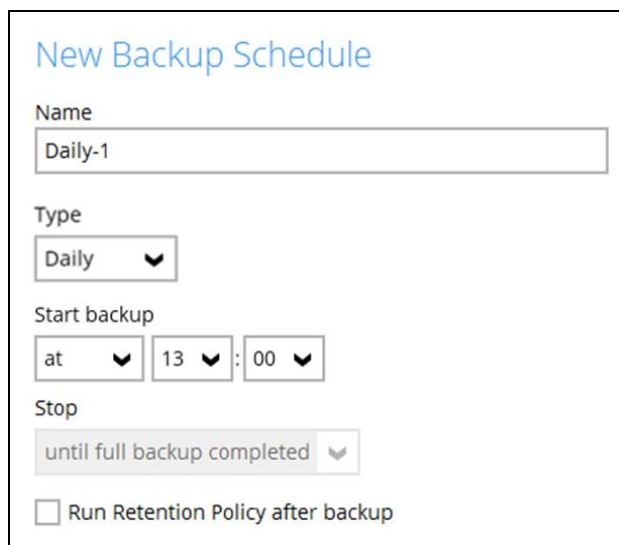

5. In the New Backup Schedule window, configure the following backup schedule settings.

- **Name** – the name of the backup schedule.

- ④ **Type** – the type of backup schedule. There are four (4) different types of backup schedule: Daily, Weekly, Monthly and Custom.

- ④ **Daily** – the time of the day or interval in minutes/hours which the backup job will run.

New Backup Schedule

Name

Type

Start backup
 :

Stop

Run Retention Policy after backup

- ④ **Weekly** – the day of the week and the time of the day or interval in minutes/hours which the backup job will run.

New Backup Schedule

Name

Type

Backup on these days of the week
 Sun Mon Tue Wed Thu Fri Sat

Start backup
 :

Stop

Run Retention Policy after backup

- ④ **Monthly** – the day of the month and the time of that day which the backup job will run.

New Backup Schedule

Name

Type

Backup on the following day every month
 Day
 First

Start backup at
 : on the selected days

Stop

Run Retention Policy after backup

- ⦿ **Custom** – a specific date and the time of that date which the backup job will run.

New Backup Schedule

Name: Custom-1

Type: Custom

Backup on the following day once: 2020 June 31

Start backup at: 23 : 59

Stop: until full backup completed

Run Retention Policy after backup

- ⦿ **Start backup** – the start time of the backup job.
 - ⦿ **at** – this option will start a backup job at a specific time.
 - ⦿ **every** – this option will start a backup job in intervals of minutes or hours.

Start backup: every 1 minute

Stop: until full backup completed

Run Retention Policy after backup

Start backup: every 1 minute

Stop: until full backup completed

Run Retention Policy after backup

Here is an example of a backup set that has a periodic and normal backup schedule.

New Backup Schedule

Name: Weekly-1

Type: Weekly

Backup on these days of the week: Sun Mon Tue Wed Thu Fri Sat

Start backup: every 4 hours

Stop: until full backup completed

Run Retention Policy after backup

Figure 1.1

New Backup Schedule

Name: Weekly-2

Type: Weekly

Backup on these days of the week: Sun Mon Tue Wed Thu Fri Sat

Start backup: at 21 : 00

Stop: until full backup completed

Run Retention Policy after backup

Figure 1.2

Figure 1.1 – Periodic backup schedule runs every 4 hours from Monday – Friday during business hours

Figure 1.2 – Normal backup schedule runs at 21:00 or 9:00 PM on Saturday and Sunday on weekend non-business hours

- **Stop** – the stop time of the backup job. This only applies to schedules with start backup “at” and is not supported for periodic backup schedule (start backup “every”)
 - **until full backup completed** – this option will stop a backup job once it is complete. This is the configured stop time of the backup job by default.
 - **after (defined no. of hrs.)** – this option will stop a backup job after a certain number of hours regardless of whether the backup job has completed or not. This can range from 1 to 24 hrs.

The number of hours must be enough to complete a backup of all files in the backup set. For small files in a backup, if the number of hours is not enough to back up all files, then the outstanding files will be backed up in the next backup job. However, if the backup set contains large files, this may result in partially backed up files.

For example, if a backup has 100GB file size which will take approximately 15 hours to complete on your environment, but you set the “stop” after 10 hours, the file will be partially backed up and cannot be restored. The next backup will upload the files from scratch again.

The partially backed up data will have to be removed by running the data integrity check.

As a general rule, it is recommended to review this setting regularly as the data size on the backup machine may grow over time.

- **Run Retention Policy after backup** – if enabled, the AhsayOBM will run a retention policy job to remove files from the backup destination(s) which have exceeded the retention policy after performing a backup job. To save hard disk quote in the long run, it is recommended to enable this option.

As an example, the four types of backup schedules may look like the following:

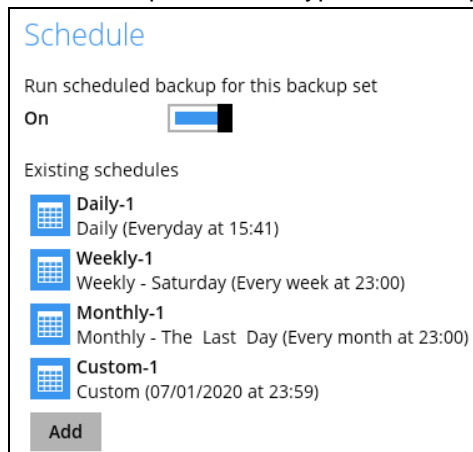

6. Click **Save** to confirm your settings once done.

7 Contact Ahsay

7.1 Technical Assistance

To contact Ahsay support representatives for technical assistance, visit the Partner Portal:
<https://www.ahsay.com/partners/>

Also use the Ahsay Wikipedia for resource such as Hardware Compatibility List, Software Compatibility List, and other product information:
<https://wiki.ahsay.com/>

7.2 Documentation

Documentations for all Ahsay products are available at:
https://www.ahsay.com/jsp/en/home/index.jsp?pageContentKey=ahsay_downloads_documentation_guides

You can send us suggestions for improvements or report on issues in the documentation, by contacting us at:
<https://www.ahsay.com/partners/>

Please specify the specific document title as well as the change required/suggestion when contacting us.